

2012-2015 Gen 3 Ford F-59 Strip Chassis Liquid Propane Autogas Fuel System – Single Side Saddle Tank

Revision History		
-AA	Initial Release	10/05/2015

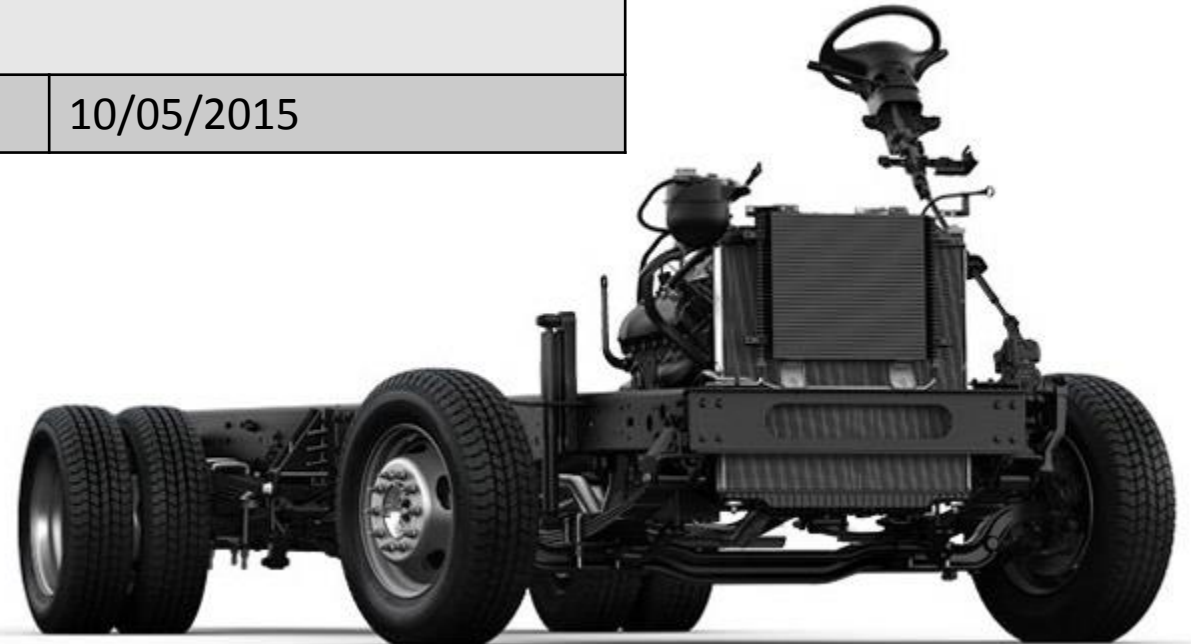

CONTENTS

PAGE 5: PREPARING THE VEHICLE

PAGE 6: REMOVING THE OEM FUEL TANK

PAGE 7: REMOVING THE OEM REAR FUEL LINES AND VAPOR LINES

PAGE 8: CAPPING OFF THE VAPOR CANISTER GASOLINE VENT PORT

PAGE 9: REMOVING THE OEM FORWARD FUEL SUPPLY LINE AND MODIFYING THE VAPOR LINE

PAGES 10-12: PREPARING ENGINE COMPARTMENT

PAGE 13: INSTALLING THE VAPOR HOSE ASSEMBLY

PAGES 14-16: INSTALLING NEW FUEL RAILS

PAGES 17-18: INSTALLING THE ENGINE SUPPLY LINE RETENTION BRACKET

PAGE 19: INSTALLING ENGINE FUEL RAIL SUPPLY LINE AND CONNECTING THE FRPCM

PAGE 20: INSTALLING THE FORWARD FUEL LINES

PAGES 21-22: MODIFYING THE OEM TRANSMISSION DIP STICK TUBE BRACKET

PAGE 23: INSTALLING ENGINE FUEL RAIL RETURN LINE

PAGE 24: INSTALLING NEW TRANS DIP STICK TUBE BRACKET WITHOUT IMRAC GUARD COVER

PAGE 25: INSTALLING NEW TRANS DIP STICK TUBE BRACKET WITH IMRAC GUARD COVER

PAGE 26: RE-INSTALLING THE TRANSMISSION VENT HOSE

PAGE 27: INSTALLING FUEL RAIL PRESSURE CONTROL MODULE (FRPCM)

PAGE 28: CONNECTING THE FRPCM FUEL LINES AND INSTALLING VAPOR PURGE HOSE ASSEMBLY

CONTENTS CONT.

- PAGE 29: FORWARD FUEL LINE AND VAPOR HOSE RETENTION
- PAGE 30: INSTALLING THE NEW PCV HOSE
- PAGE 31: INSTALLING THE SMART RELAY MODULE (SRM)
- PAGES 32-33: DRILLING THE FRAME FOR MOUNTING THE TANK
- PAGES 34-36: DRILLING ADDITIONAL HOLES
- PAGE 37: ASSEMBLING THE FILL FILTER
- PAGE 38: INSTALLING THE FILL SYSTEM – FILL FILTER
- PAGE 39: PREPARING THE TANK
- PAGE 40: INSTALLING THE TANK
- PAGE 41: INSTALLING THE INTERMEDIATE SUPPLY LINE
- PAGE 42: INSTALLING THE INTERMEDIATE RETURN LINE
- PAGE 43: INSTALLING THE REAR RETURN LINE
- PAGE 44: INSTALLING THE REAR SUPPLY LINE
- PAGE 45: CONNECTING THE SUPPLY AND RETURN VALVES TO THE REAR LINES.
- PAGE 46: ASSEMBLING THE FILL VALVE (EURO VALVE)
- PAGE 47: ASSEMBLING THE FILL VALVE (ACME VALVE)
- PAGES 48-53: INSTALLING THE FILL SYSTEM
- PAGE 54: INSTALLING THE NEW ELECTRONIC FUEL PUMP RELAY (EFPR)

CONTENTS CONT.

PAGES 55-56: INSTALLING THE TANK VALVE GUARD

PAGE 57: INSTALLING THE SRM/FUSE BLOCK WATER DRIP SHIELD

PAGE 58: HARNESS RETENTION IDENTIFICATION

PAGE 59: FRONT HALF HARNESS ROUTE OVERVIEW

PAGES 60-62: CAN HARNESS

PAGES 63-73: UNDER HOOD HARNESS

PAGE 74: REAR HALF HARNESS ROUTE OVERVIEW

PAGES 75-82: REAR FRAME HARNESS

PAGES 83-84: TANK HARNESS

PAGES 85-89: INSTALLING BADGES AND LABELS

PAGE 90: COMPLETING THE KIT INSTALLATION

PAGE 91: SPECIAL TOOLS

PAGE 92: TANK MOUNTING REFERENCE MEASUREMENTS

PREPARING THE VEHICLE

1. Using a scan tool, check for all diagnostic trouble codes. Correct all trouble codes before continuing.
2. Depressurize the fuel rails using the procedure described in the *Ford Workshop Manual Section 310-00 Fuel System, General Information*.
3. Disconnect the battery terminals and remove the battery.
4. Disconnect the OEM PCM harness push-pin to allow easier ROUSH CleanTech under hood harness installation.
5. Disconnect the mass air flow (MAF) sensor connector and remove the air cleaner assembly including the air filter cover, degas bottle hose, air box and intake air box adapter. Separate the air cleaner cover, MAF sensor and air box from the adapter independently.

REMOVING THE OEM FUEL TANK

Refer to the *Ford Workshop Manual, Section 310-01, Fuel Tank and Lines*, for instructions on removing the original fuel tank, tank shield and hardware.

Note: Remove only the fuel and vapor lines, do NOT remove the brake lines when following the *Ford Workshop Manual* procedure.

1. Disconnect the fuel tank filler pipe and vent hose from fuel tank.
2. Disconnect vapor line and fuel supply line from fittings at tank and frame rail.
3. Disconnect all wiring connections from tank.
4. Remove tank mounting bolts and drop/remove tank and shield.

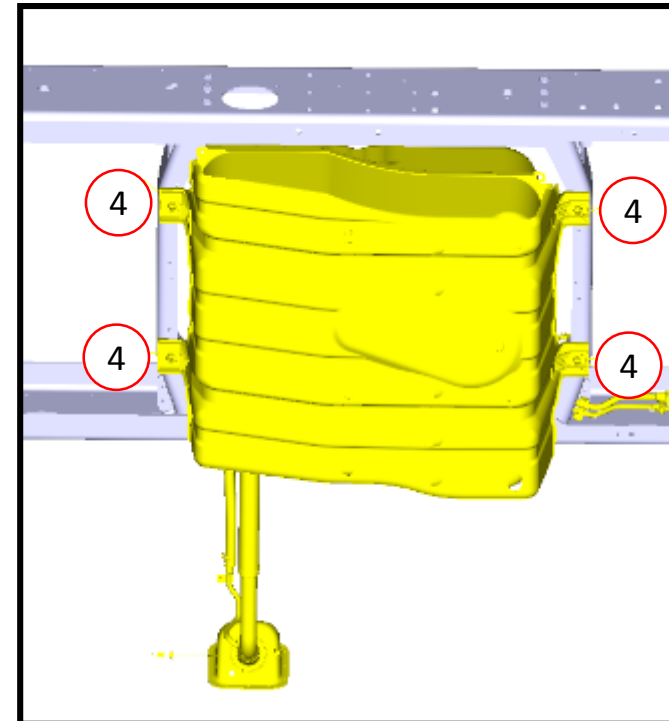
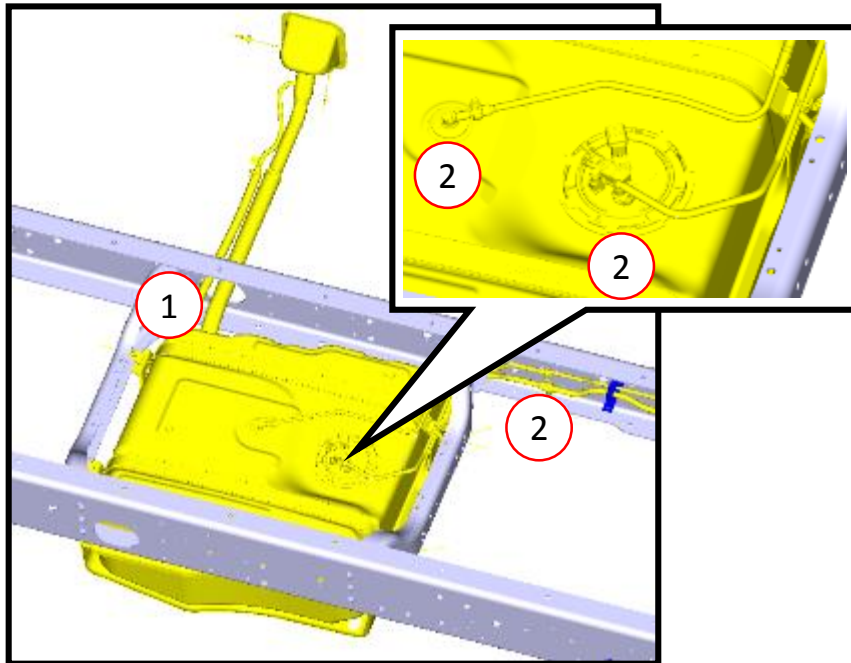

REMOVING THE OEM REAR FUEL LINES AND VAPOR LINES

1. Disconnect the vapor line that is aft of the vapor canister from the vapor canister.
2. Disconnect the gasoline supply fuel line near the transmission.
3. Remove the fuel line and disconnected vapor line from clips, do not remove or discard clips.

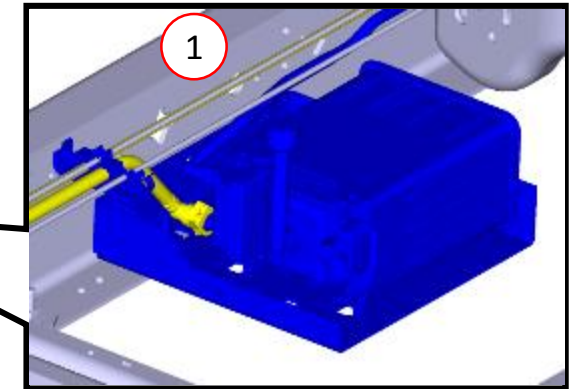
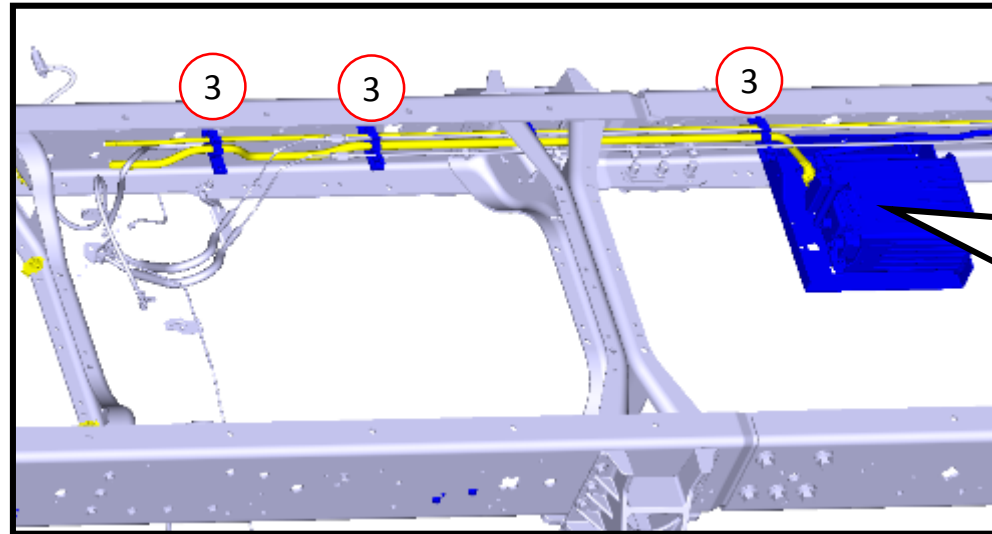
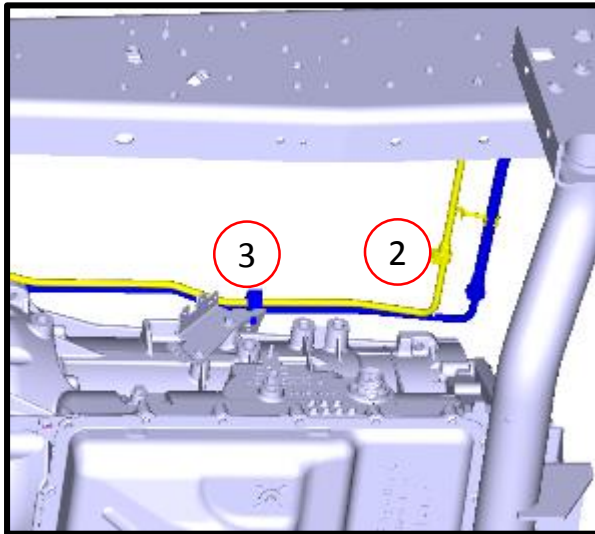

CAPPING OFF THE VAPOR CANISTER GASOLINE VENT PORT

1. Cap off the port on the vapor canister port that you removed the vapor line from using the vacuum cap MR0150 and quick connect fitting 203576 found in the hardware kit **P15MB-VAPOR-A**.

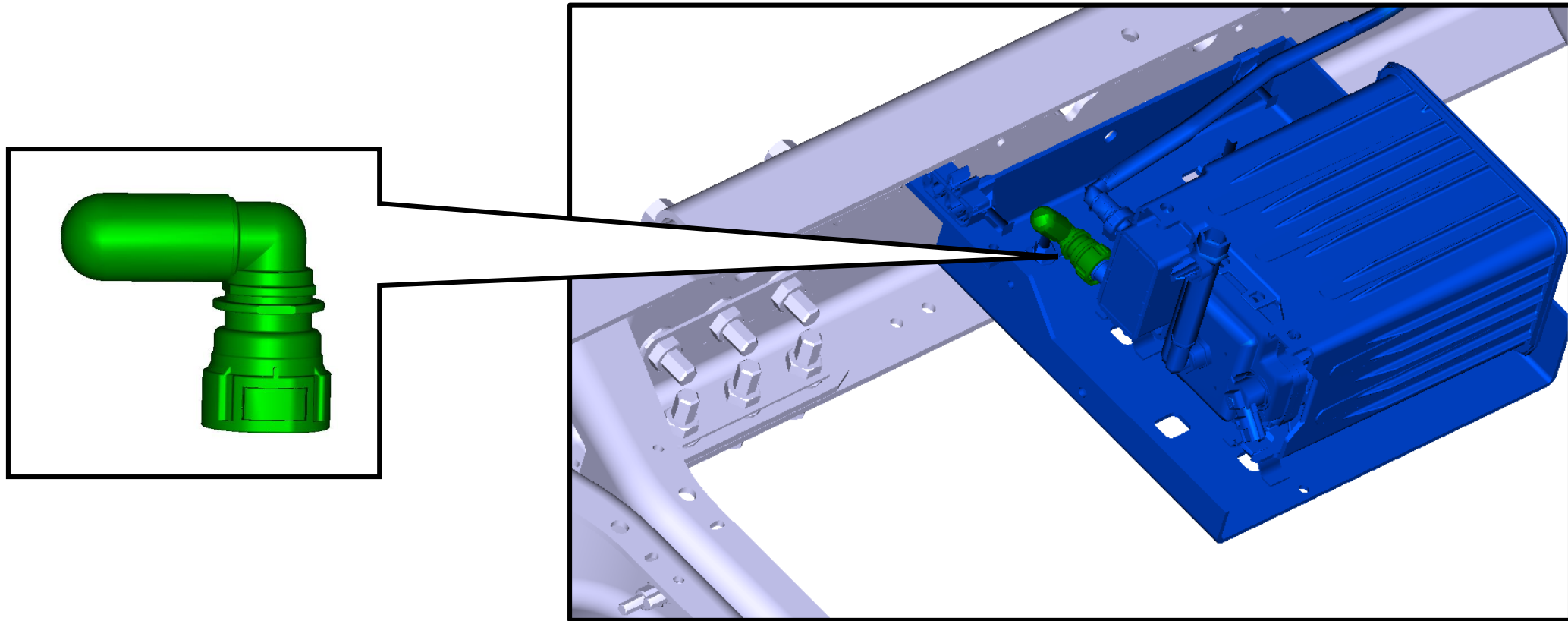

REMOVING THE OEM FORWARD FUEL SUPPLY LINE AND MODIFYING THE VAPOR LINE

1. Disconnect fuel rail supply.
2. Open fuel line retention clip (do not remove) and remove fuel supply line.
3. Disconnect the vapor line from the Vapor Management Valve (VMV).
4. Cut the vapor line 2.5" from the vertical as shown below and discard the top portion but save the VMV.

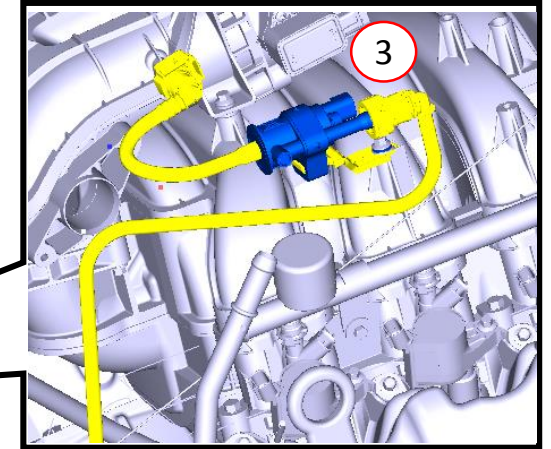
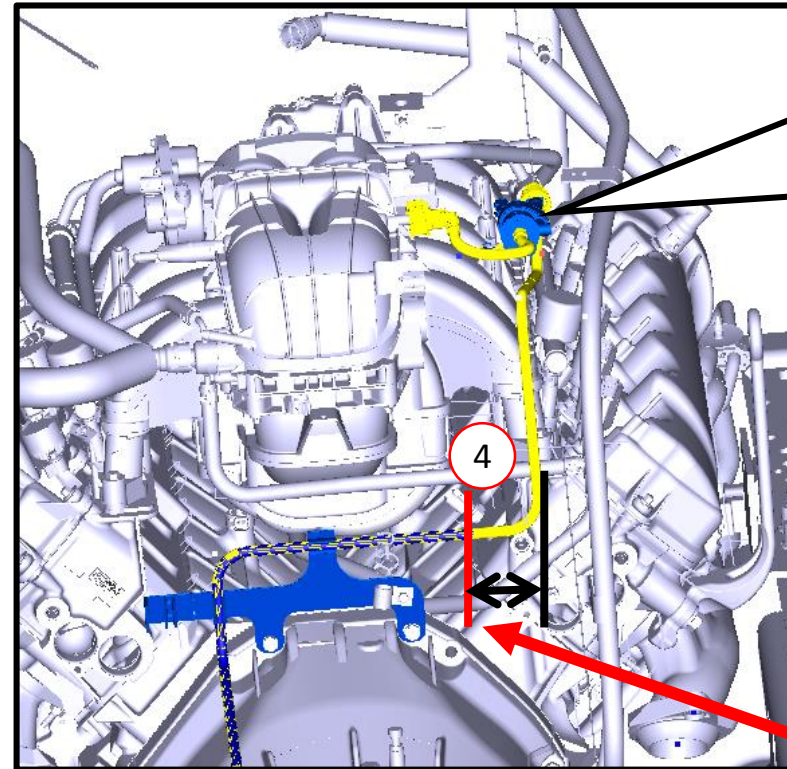
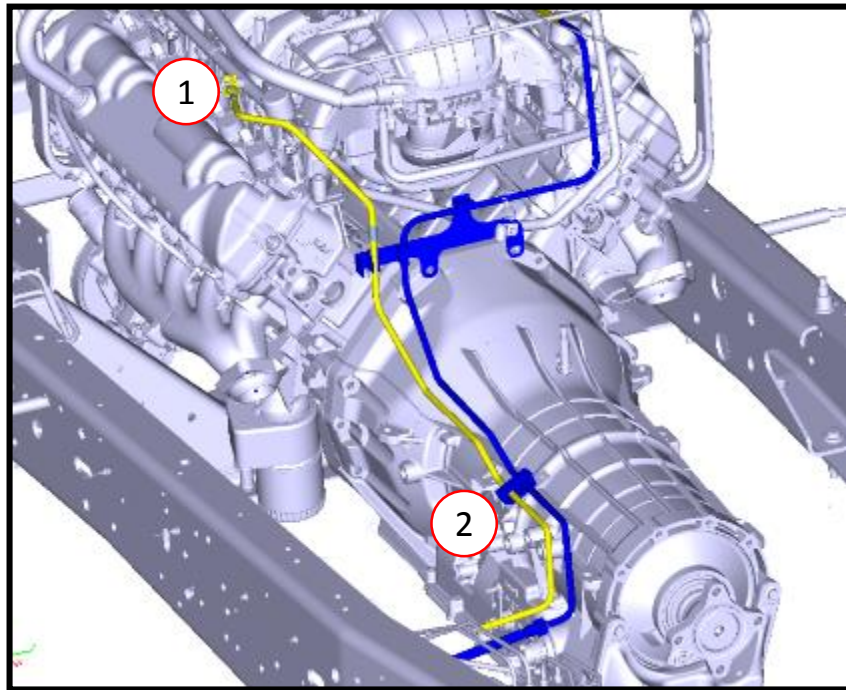

Cut here 2.5" from the vertical and discard upper portion but save the VMV.

PREPARING ENGINE COMPARTMENT

Refer to the *Ford Workshop Manual, Section 303-04, Fuel Charging and Controls — 6.8L (3V)*, for complete instructions on removing the fuel rails and injectors. Some original parts will be reused. The components in this section may be saved, discarded or new. Refer to color key.

1. Disconnect the intake manifold runner control (IMRC) actuator electrical connector as needed. **Figure 6.1.**
2. Unplug the electrical harness connector from OEM VMV.
3. Disconnect the VMV hose quick-connect fitting from the throttle body adapter. **Figure 6.2.**
4. Remove the bolt securing the bracket and remove the VMV assembly (hose, VMV and bracket) for modification. **Figure 6.2.**
5. Separate the hose with quick-connect from the VMV. Pull the OEM VMV bracket out of the VMV. Discard the hose, bracket and bolt. **Figure 6.3.**
6. A new VMV mounting bracket found in hardware kit **P15MB-ENGKIT-A** is to be installed onto the FRPCM. The VMV and rubber isolator will be pushed onto the new bracket after the bracket has been installed. **Figure 6.3.**
7. Slide the abrasion sleeve onto the VMV engine purge hose. Connect the VMV engine purge hose assembly to the VMV and secured with a stepless ear clamp (labeled "18"). **Note:** This clamp should NOT be tightened until after the orientation between the VMV and hose is correct with the assembly installed. **Figure 6.4.**



Figure 6.1

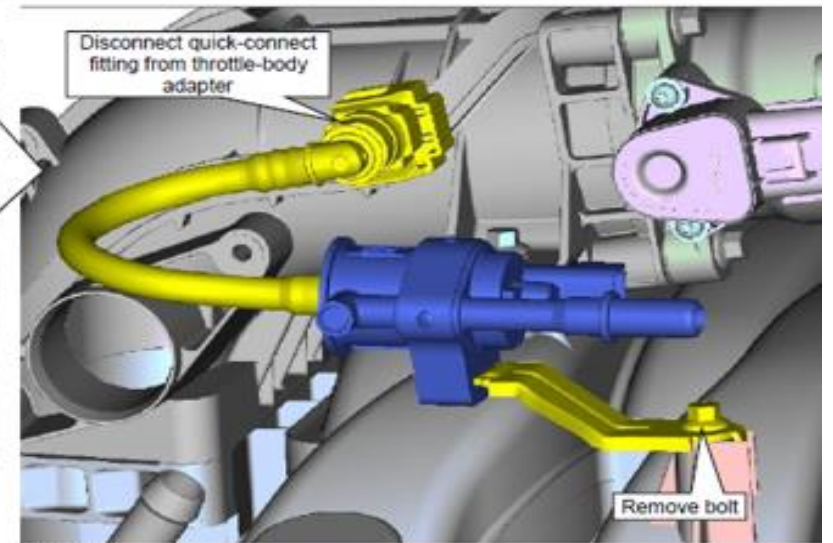

Figure 6.2

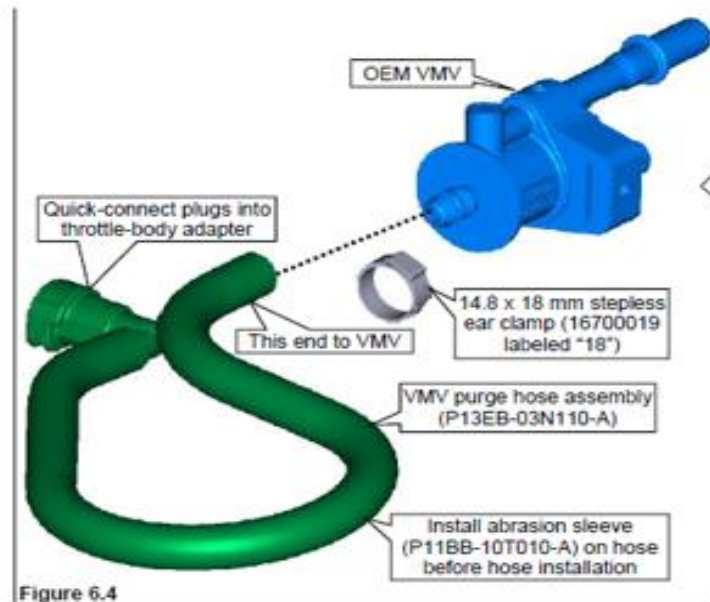

Figure 6.4

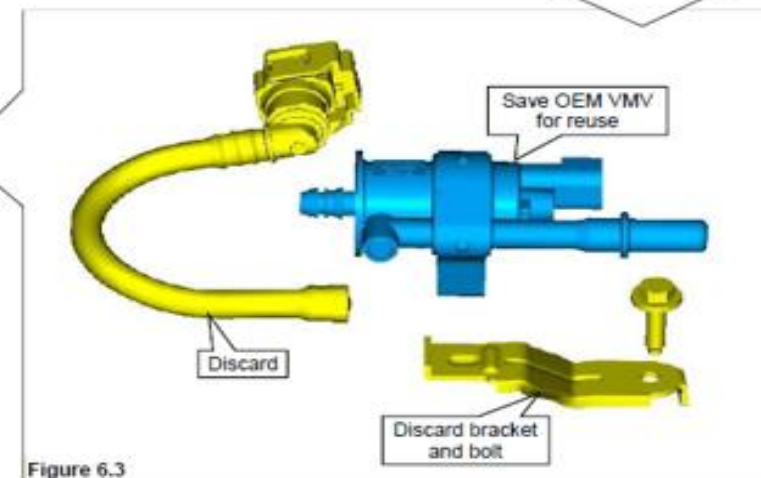
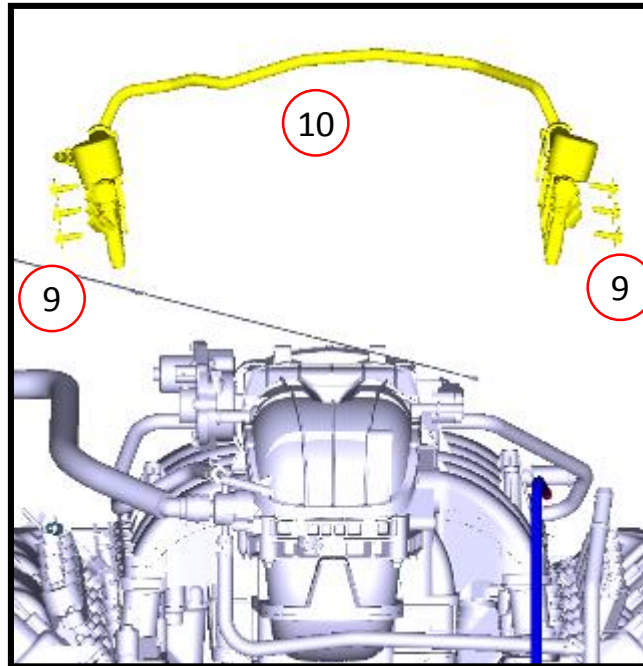

Figure 6.3

PREPARING THE ENGINE COMPARTMENT CONT.

7. If necessary, remove the engine wiring harness from the mounting studs on the valve cover.
8. Disconnect electrical connector from each OEM fuel injector.
9. Remove the six fuel rail mounting bolts and fuel rail assembly (with crossover hose).
10. Discard fuel rail assembly and bolts.



PREPARING THE ENGINE COMPARTMENT CONT.

11. Remove the PCV hose that connects the right hand crank cover to the clean air hose.

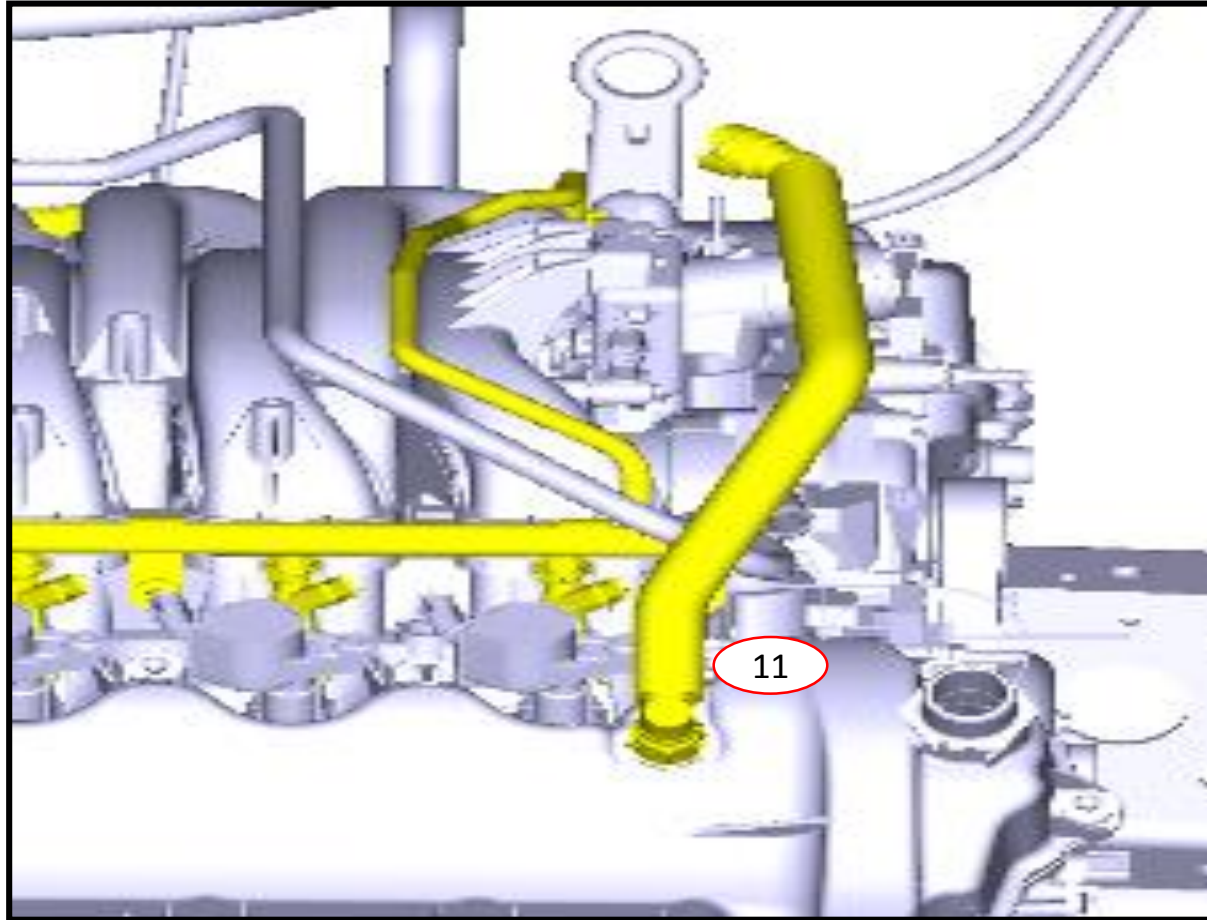

INSTALLING THE VAPOR HOSE ASSEMBLY

1. Attach the vapor hose assembly P15MB-03N100-A to the modified OEM steel vapor line as shown below.
2. Secure with stepless ear clamp 11-054-0147.
3. Retain using the dual clamp zip tie 20-403-0004 to the dip stick tube.

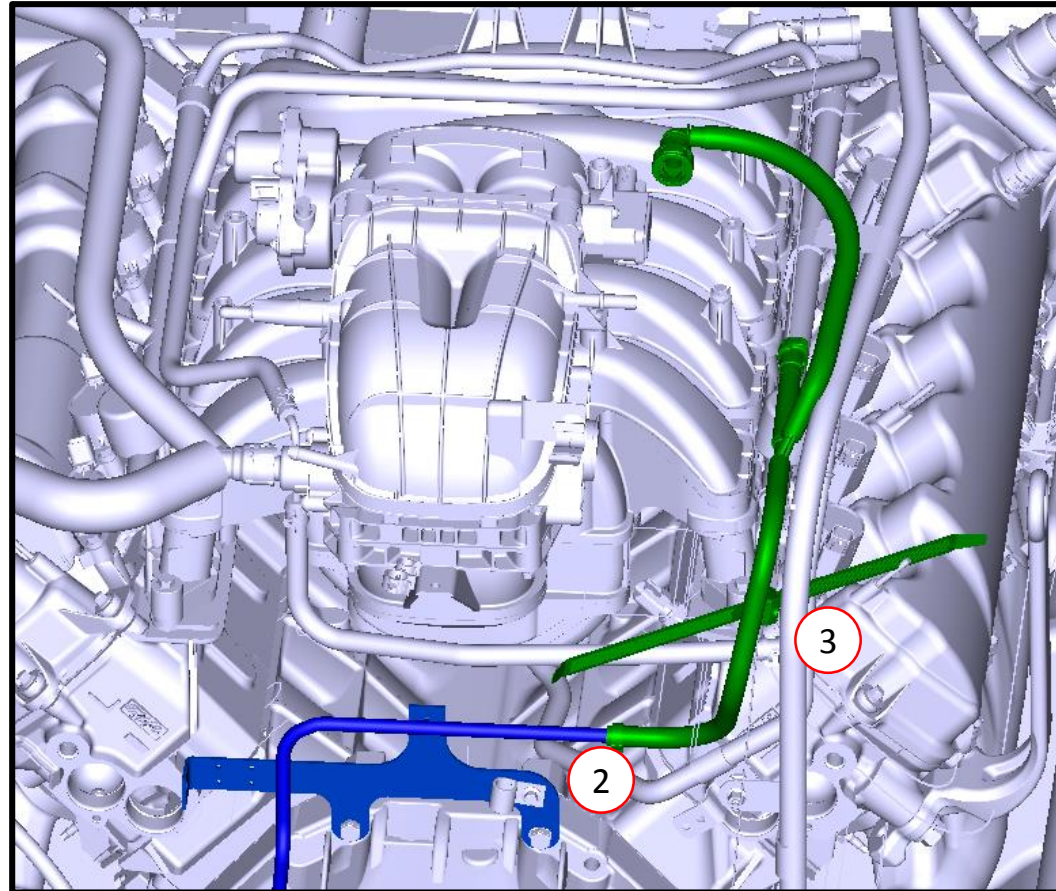

INSTALLING NEW FUEL RAILS

1. If necessary, disconnect coil electrical wires (and ignition coils if necessary) for clearance.
2. Install three fuel rail mounting brackets to each fuel rail. Tighten the screws to 8–12 Nm. **Figures 8.2 and 8.5.**
3. Using engine oil (Motorcraft SAE 5W-20 or equivalent), lubricate lower O-rings on injector nozzles before seating rail assemblies.
4. Position left hand fuel rail assembly onto driver side of intake manifold and fully seat nozzles. Using three M6 x 1.0 x 16 bolts found in hardware kit **P15MB-ENGGIT-A**, secure fuel rail to intake manifold. Tighten bolts to 8–12 Nm. **Figure 8.3.**
5. Position right hand fuel rail assembly onto passenger side of intake manifold and fully seat nozzles. Using three M6 x 1.0 x 16 bolts found in hardware **P15MB-ENGGIT-A**, secure fuel rail to intake manifold. Tighten bolts to 8–12 Nm. **Figure 8.4.**

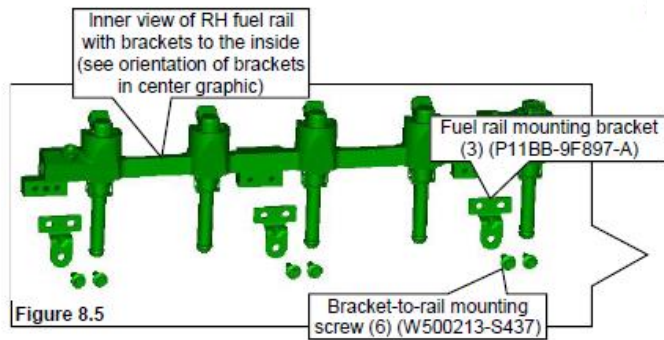

Figure 8.5

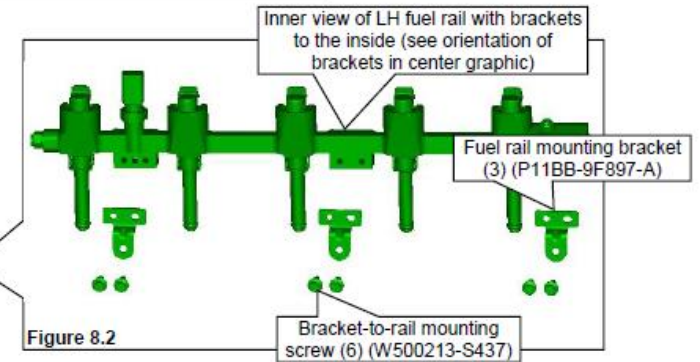
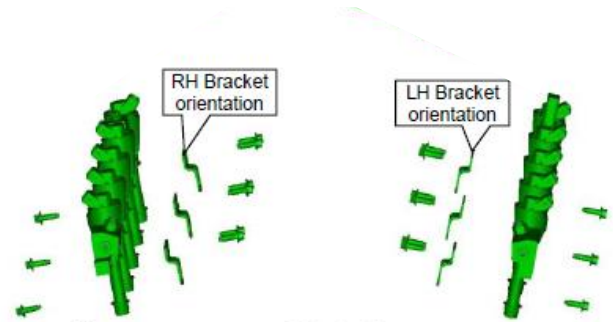

Figure 8.2

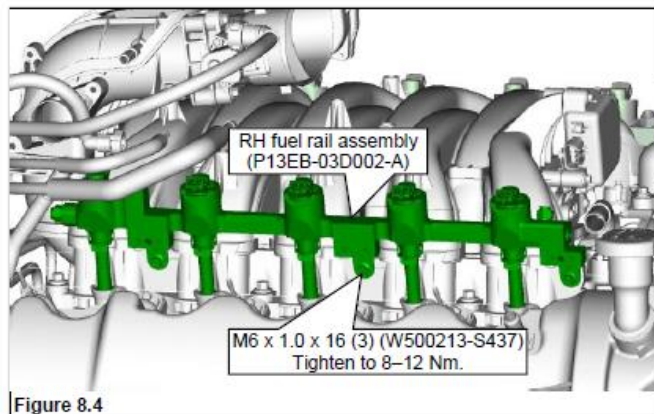

Figure 8.4

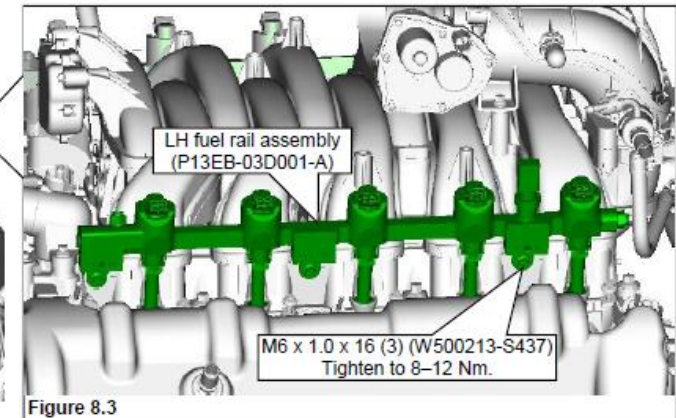
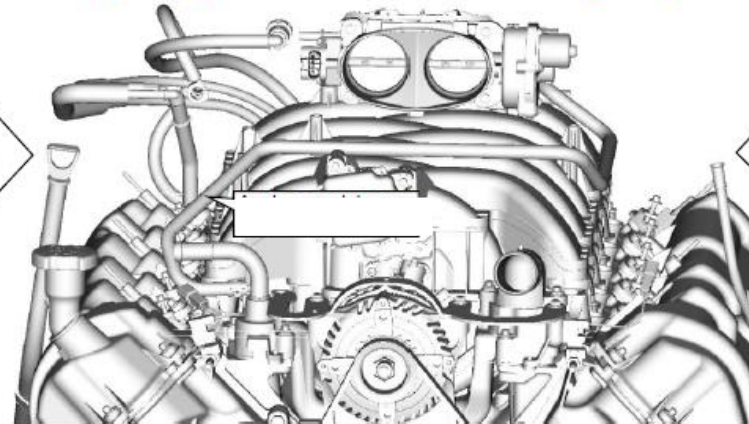
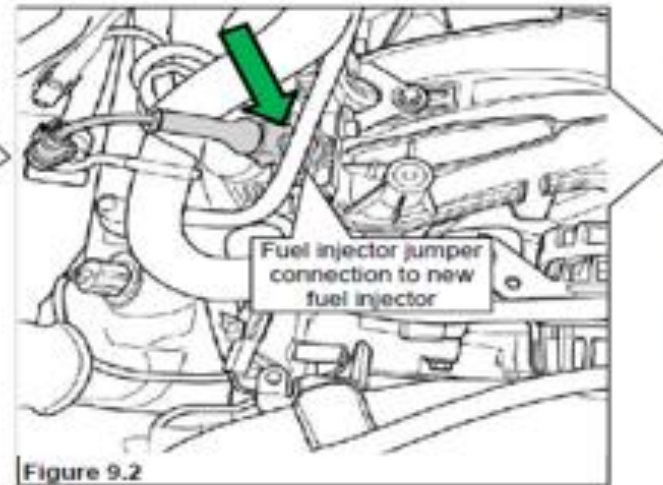
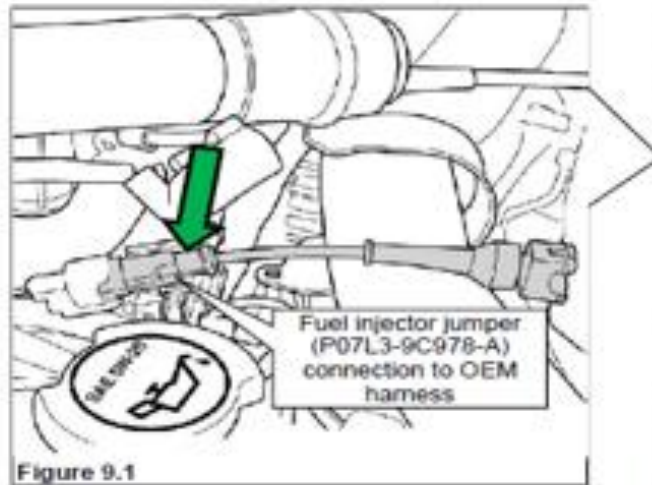

Figure 8.3

INSTALLING NEW FUEL RAILS CONT.

7. If applicable, connect coil wires.
8. Connect a fuel injector jumper to each original fuel injector harness connector. The ten jumpers can be found in hardware kit P15MB-ELECKIT-AA. Connect opposite end of each jumper to its respective fuel injector. Figures 9.1 and 9.2.
9. Connect the intake manifold runner control (IMRC) actuator electrical connector. Figure 9.3.



INSTALLING NEW FUEL RAILS CONT.

Secure the fuel injector jumpers to the OEM engine harness where applicable using zip ties found in P15MB-ELECKIT-AA.



INSTALLING THE ENGINE SUPPLY LINE RETENTION BRACKET

1. Remove OEM transmission vent hose retention bracket and discard the bracket, retention clip and bracket fastener.
2. Remove OEM dual C-Clips and set aside. These will be used when you reinstall the vent hose.

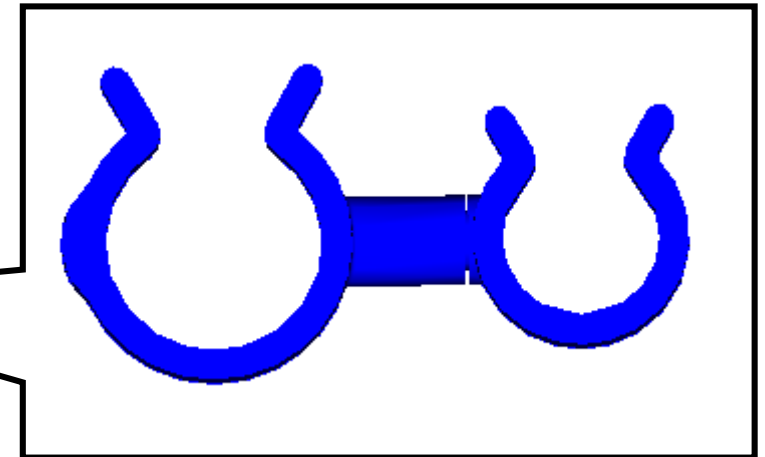
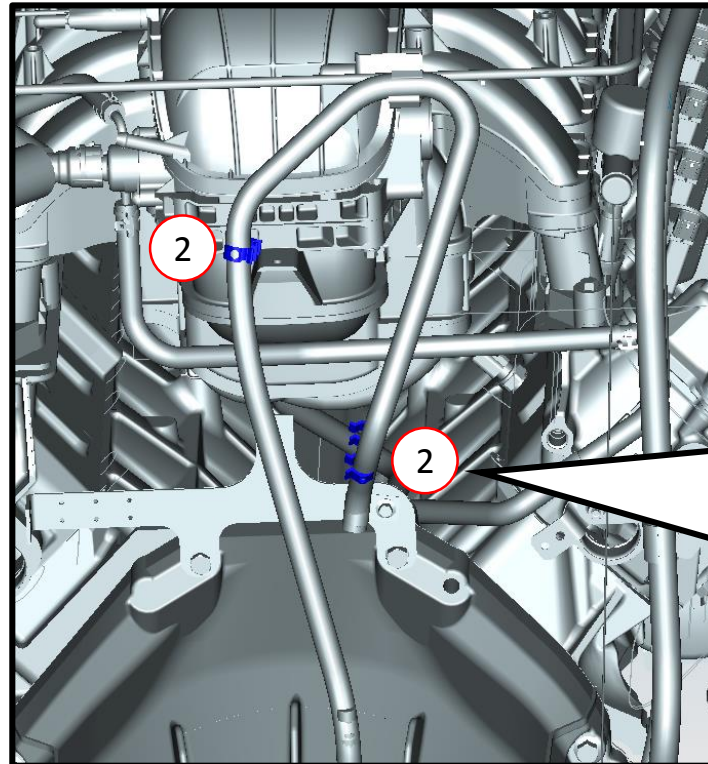
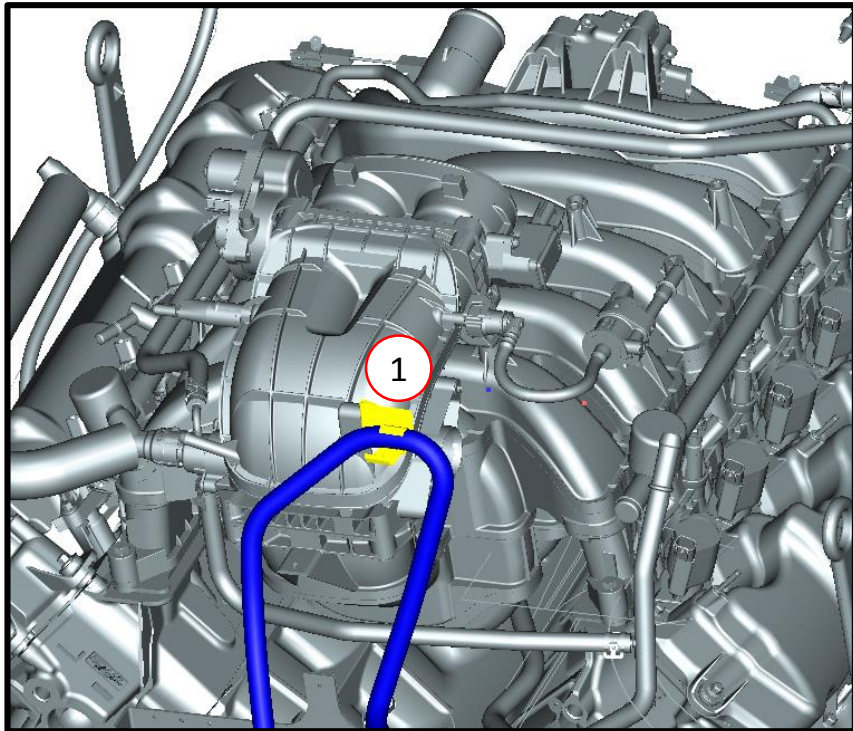

INSTALLING THE ENGINE SUPPLY LINE RETENTION BRACKET CONT.

1. Attach bracket P16MB-10F100-B to the throttle body spacer using qty. 2 bolts W500213-S437. Torque to 8-12 Nm.
2. Attach Qty. 2 J-clips W520822-S439 to the fuel line retention bracket.

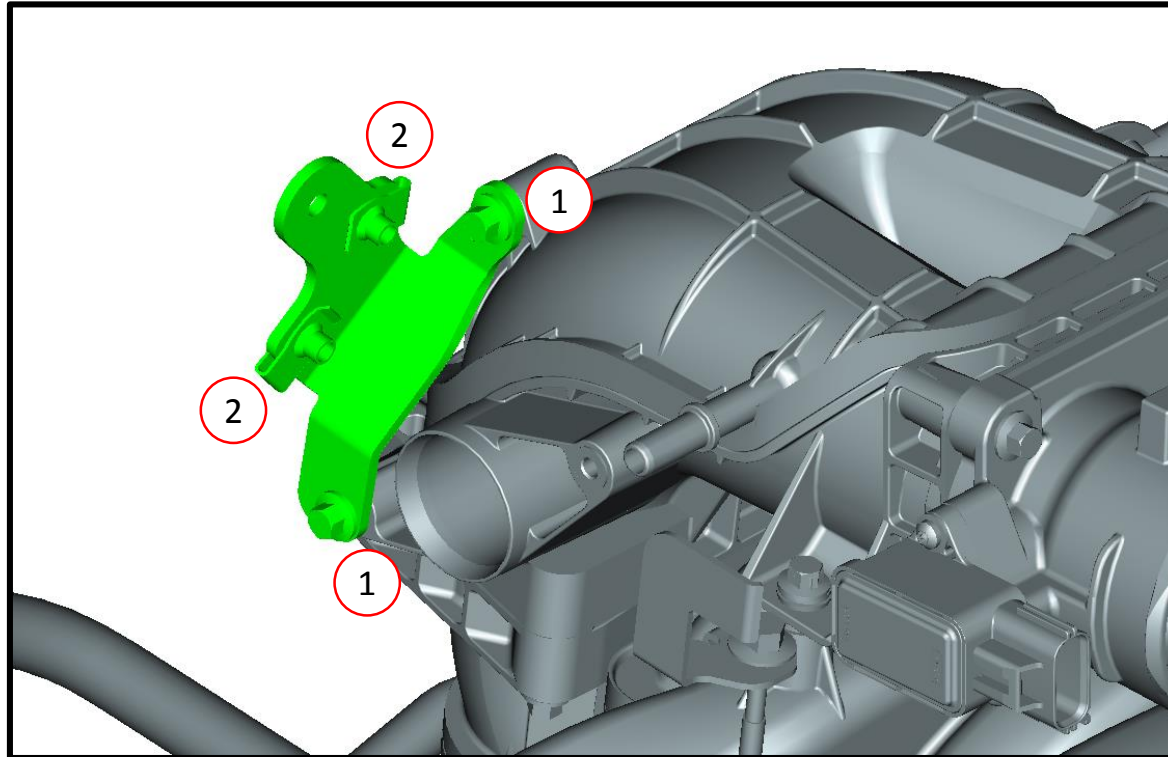

INSTALLING ENGINE FUEL RAIL SUPPLY LINE AND CONNECTING THE FRPCM

1. Orient and install fuel rail supply line assembly P12EB-03D110-A onto rearward ends of fuel rails. Push to connect fittings. The other end will connect to the FRPCM once it is installed.
2. Retain the supply line assembly to the supply line retention bracket P16MB-10F100-B using qty. 2 M6 bolts W500213-S437. Torque 8-12 Nm.

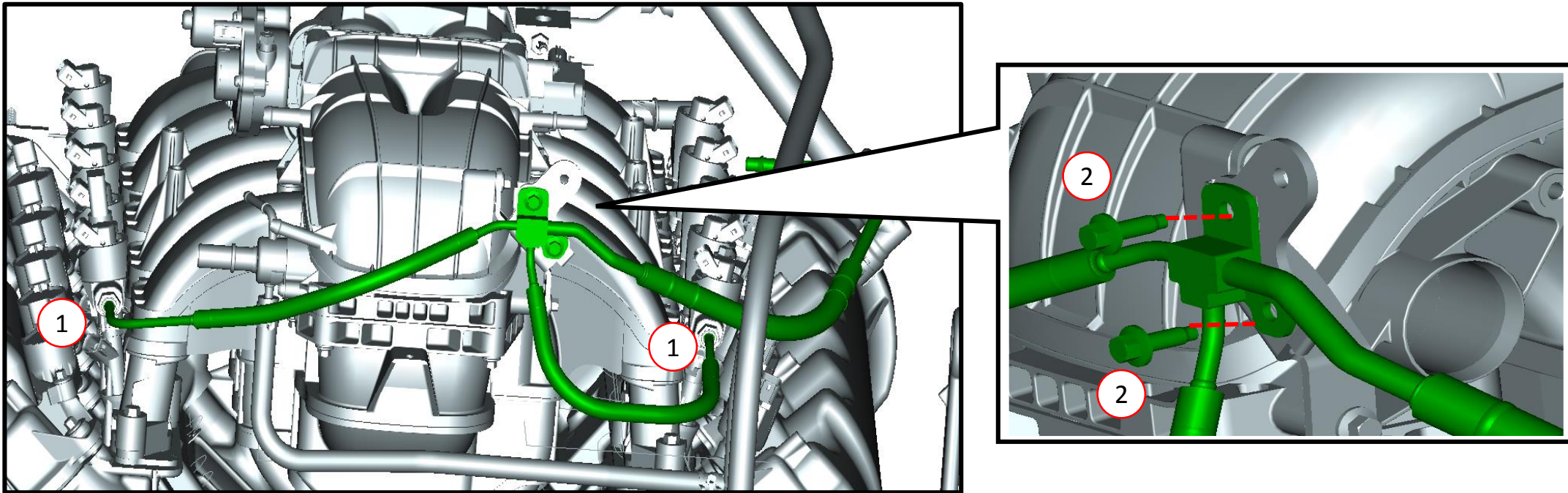

INSTALLING THE FORWARD FUEL LINES

- 1) Disconnect the shifter cable bracket located on the left side of the transmission (remove and save two bolts and disconnect the electrical connector).
Figure 5.1
 - 2) Install forward line retention bracket P15MB-10F100-A using qty. 2 M5 bolts 11-031-0583, torque 5-7 Nm. Install double snail clip 15-004175 to retention bracket.
 - 3) Install forward supply line P15MB-10S110-A as shown. Snap supply line into the OEM retention clip on the transmission and the forward line retention bracket snail clip.
 - 4) Install forward return line P15MB-10R110-A as shown. There are 3 locations for retention. The line retains to the forward line retention bracket using the snail clip. Use a zip tie retain the return line to the OEM clip on the transmission. Lastly, retain to the OEM Ford transmission bracket using a zip-tie with fir tree 155-05800.
- 1) Reinstall the shift cable bracket and connect the electrical connector.
 - 2) Tighten the two bolts and connect the electrical connector.

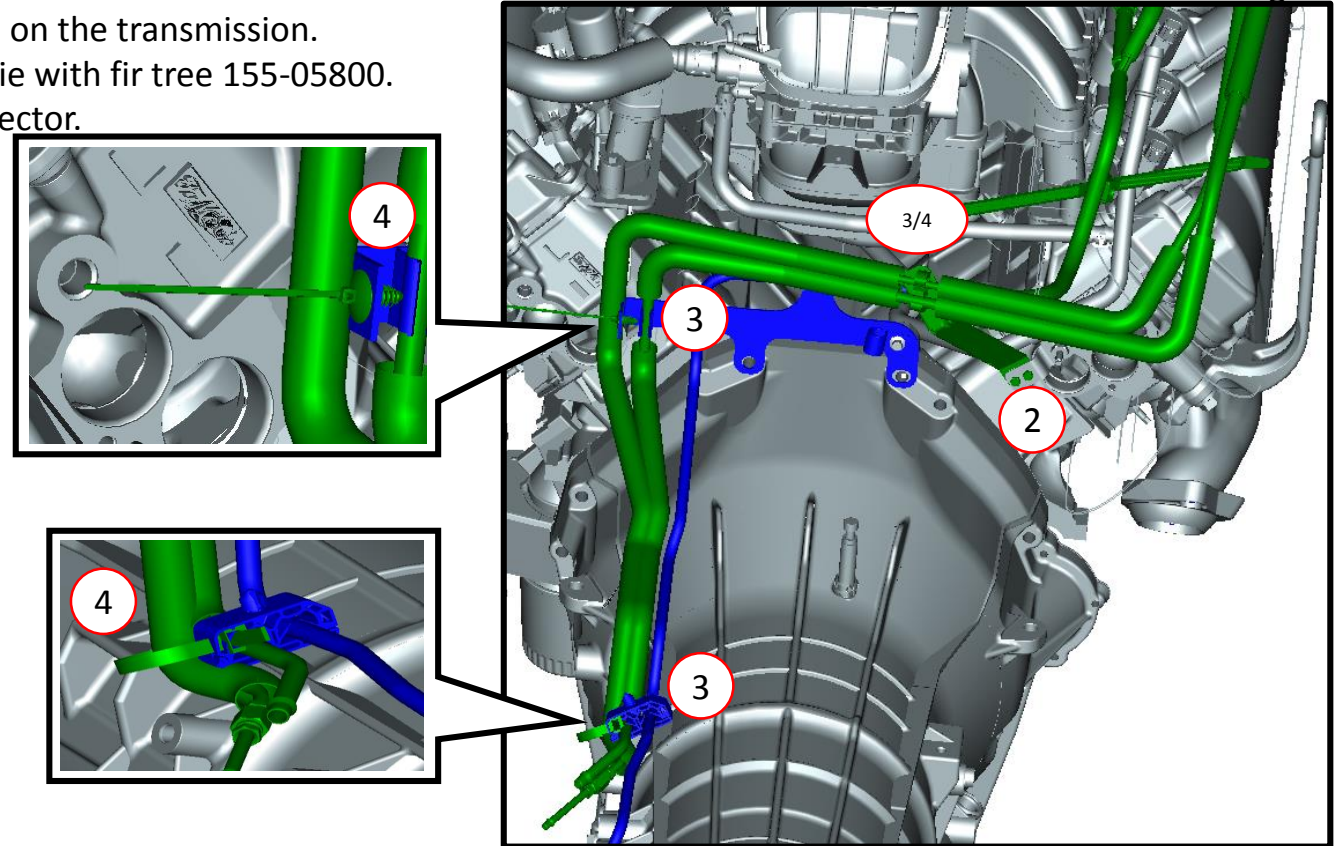
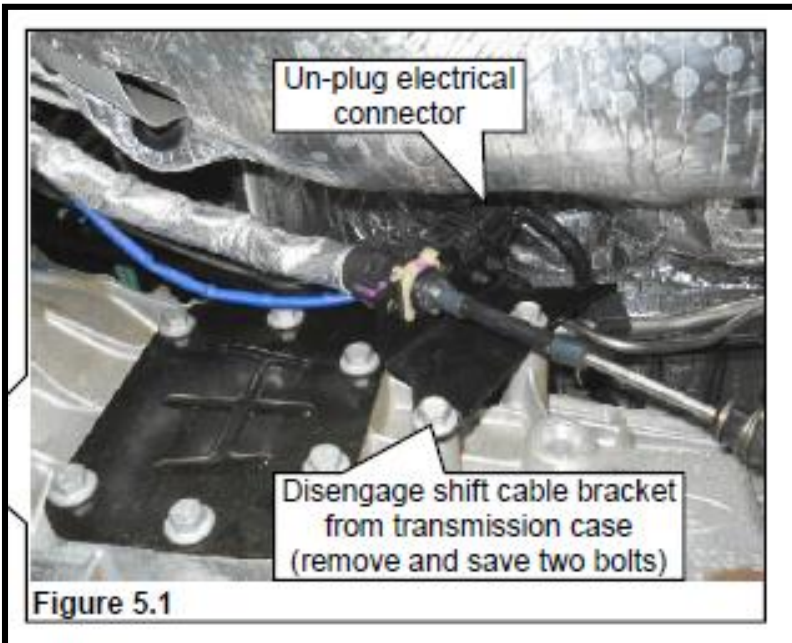

MODIFYING THE OEM TRANSMISSION DIP STICK TUBE BRACKET.

1. Locate the transmission dip stick tube bracket and measure 64 mm (2.5 Inches) down from the horizontal and cut off the lower portion of the bracket with a reciprocating saw. Loosen the bolt retaining the lower portion of the bracket and discard the lower half of the bracket. Save the bolt.

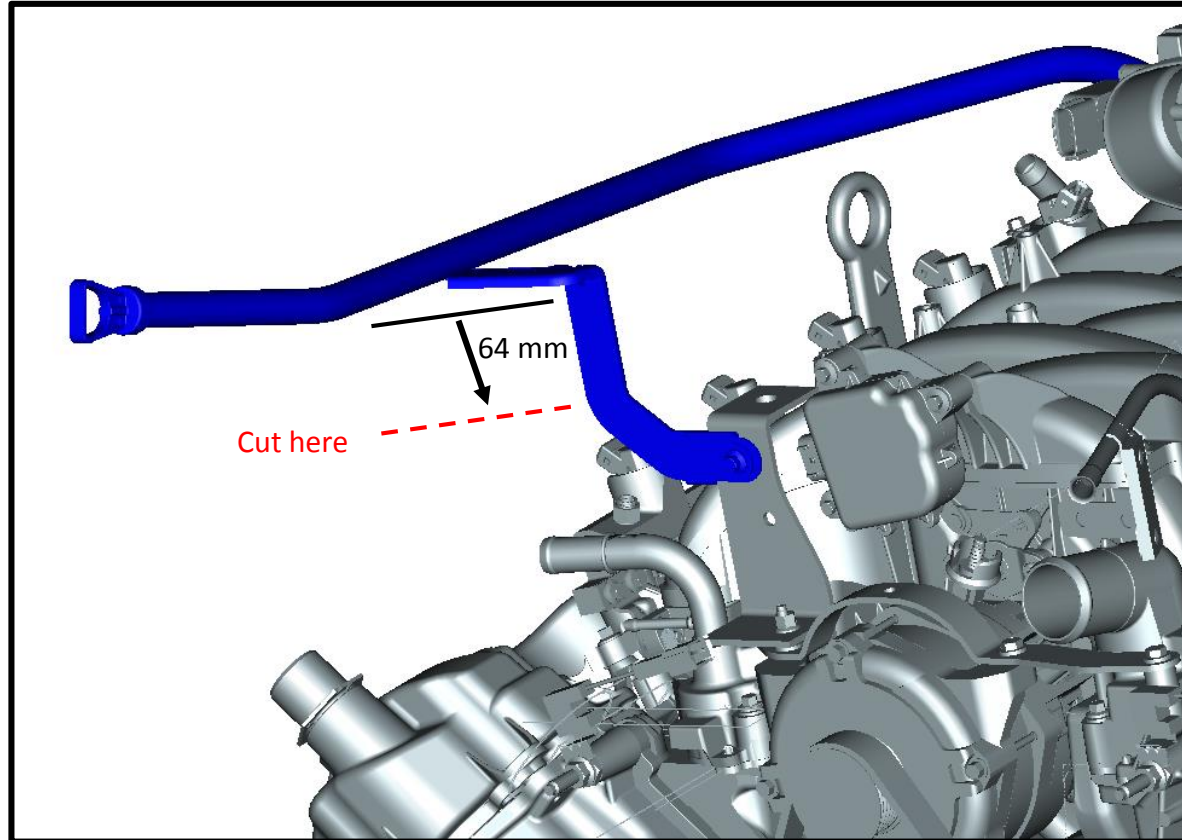

MODIFYING THE OEM TRANSMISSION DIP STICK TUBE BRACKET CONT.

1. Drill two 7 mm holes into the modified transmission dip stick tube bracket per the dimensions below.

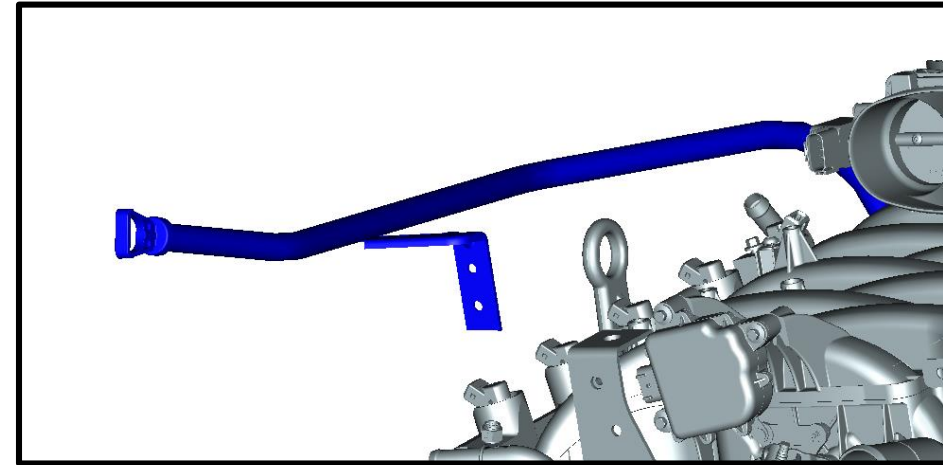
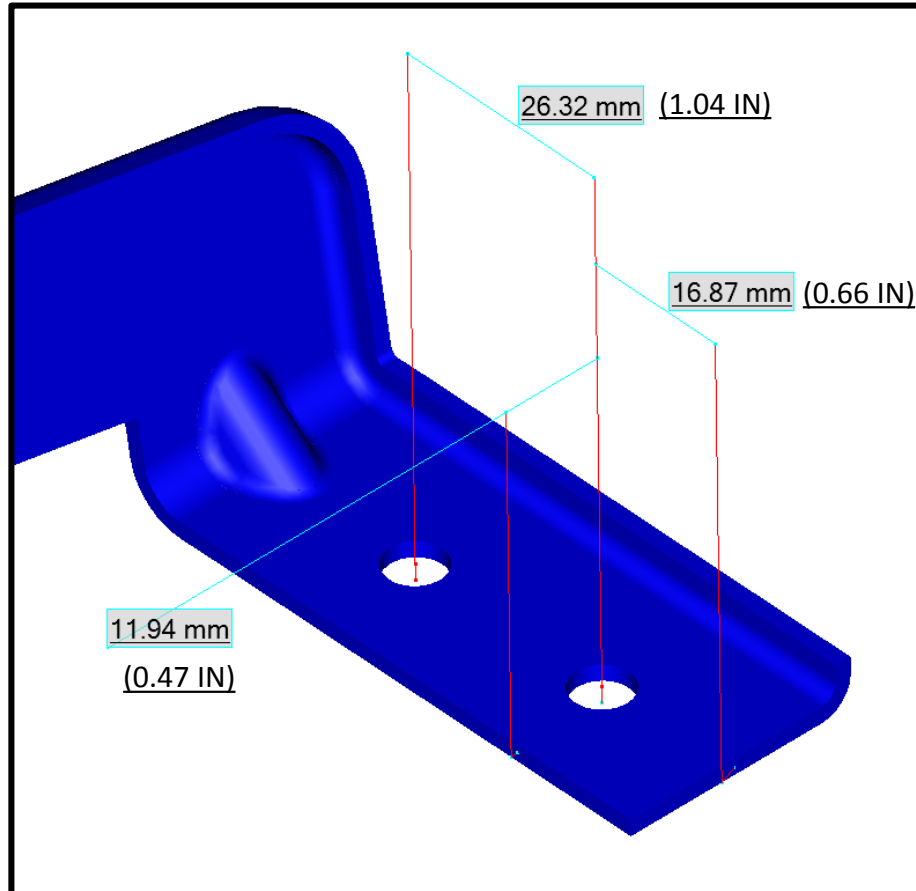

INSTALLING ENGINE FUEL RAIL RETURN LINE

1. Orient and install the engine fuel rail return line assembly P15MB-03D120-A onto forward ends of the fuel rails. Push to connect the fittings. The other branch will connect to the FRPCM once it is installed.

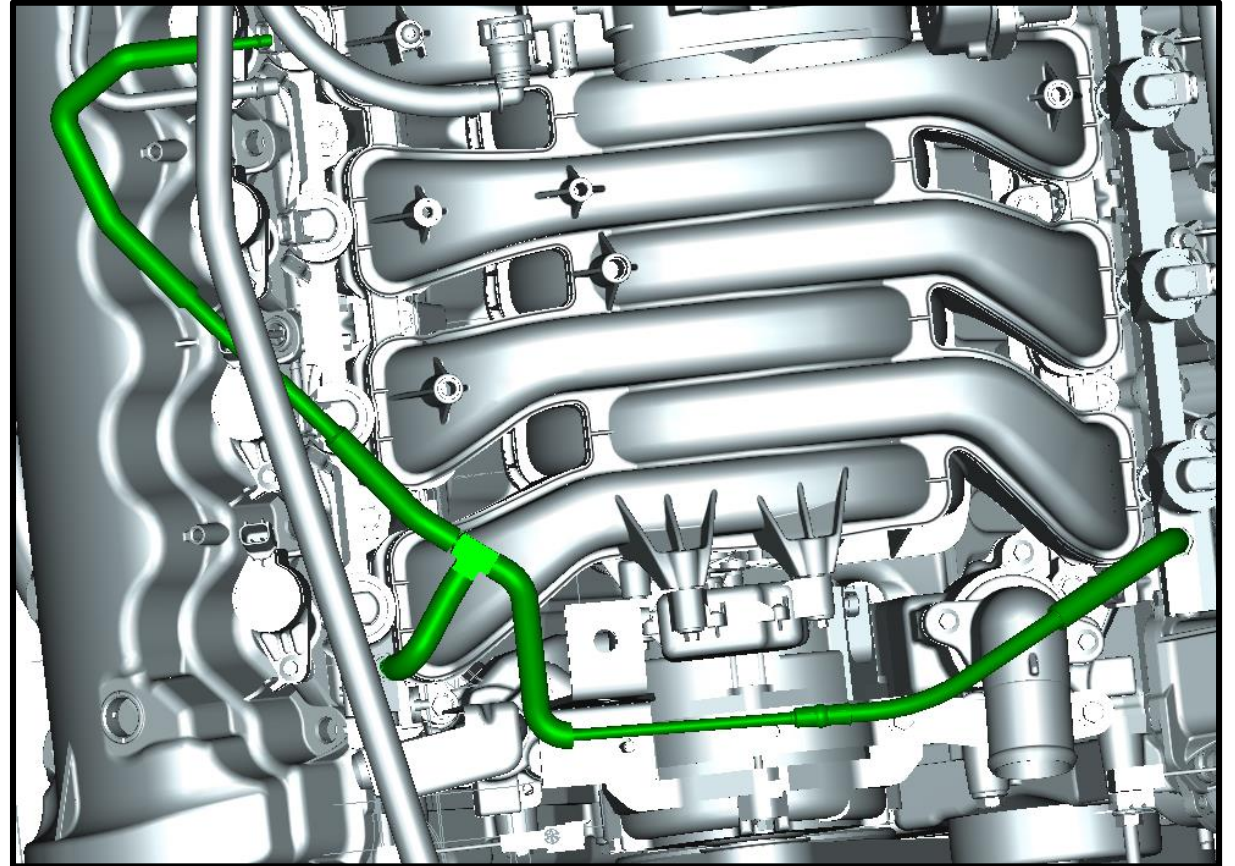
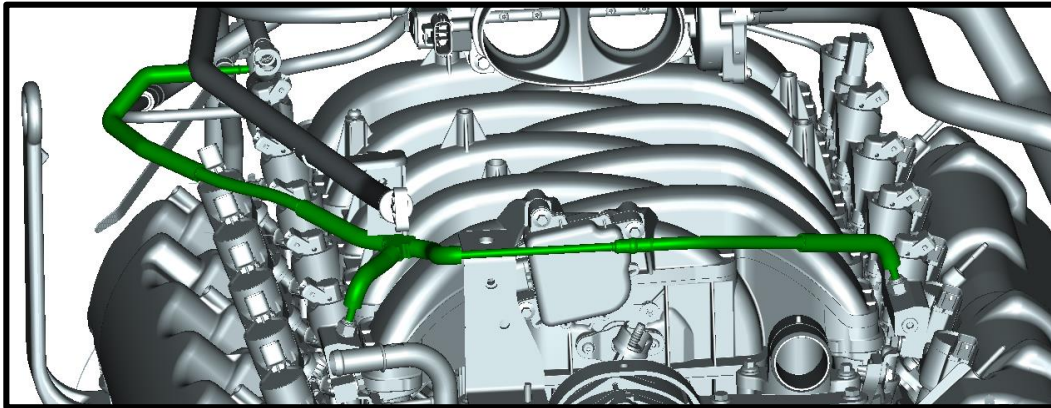

INSTALLING NEW TRANS DIP STICK TUBE BRACKET WITHOUT IMRAC GUARD COVER

1. If the vehicle has the IMRAC guard then skip to the next page.
2. Install the new transmission dip stick tube bracket P15MB-10F100-C as shown below.
3. Make sure the left hand side of the bracket mates to the modified dip stick tube bracket on the rearward face as shown. Fasten to the modified bracket using two M6 bolts W500213-S437 and two M6 nuts W702147-S. Torque 8-12 Nm.
4. The right hand side sits on the forward face of the existing support bracket. Reuse the fastener that you removed from the discarded portion of the dip stick tube bracket. Retain the engine fuel rail return line P15MB-03D120-A to the new transmission dip stick tube bracket P15MB-10F100-CA using a P-clamp 11-054-0158, an M6 bolt W500213-S437 and a M6 nut W702147-S. Torque 8-12 Nm.

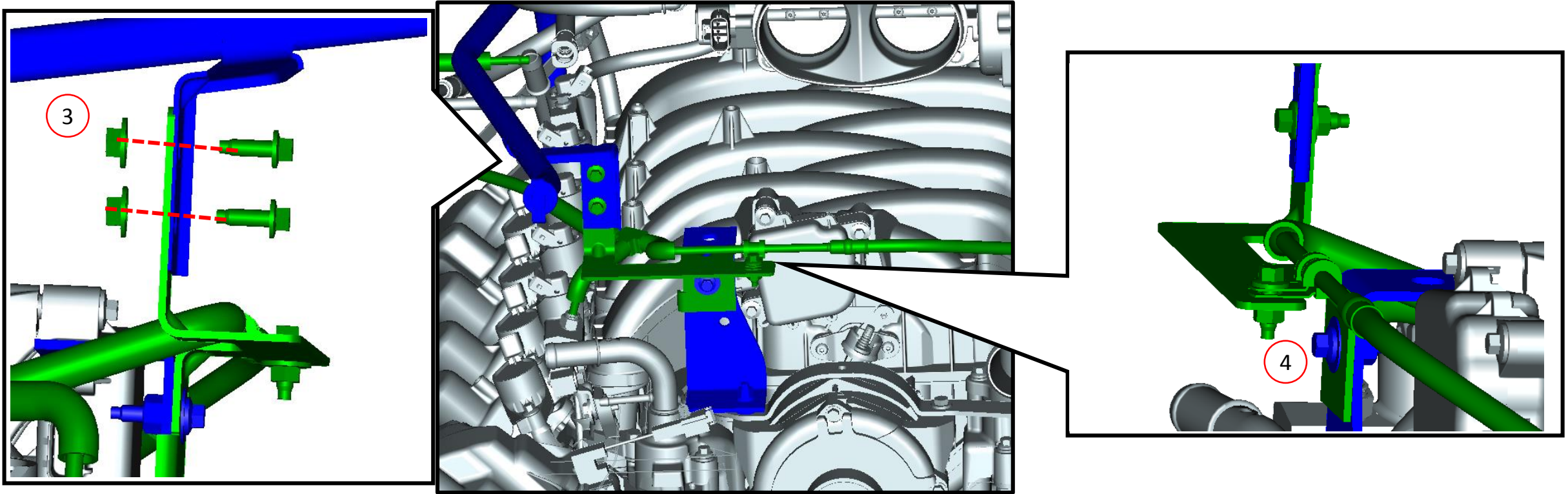

INSTALLING NEW TRANS DIP STICK TUBE BRACKET WITH IMRAC GUARD COVER

1. Install the new transmission dip stick tube bracket P15MB-10F100-C as shown below.
2. Make sure the left hand side of the bracket mates to the modified dip stick tube bracket on the forward face as shown. Fasten to the modified bracket using two M6 bolts W500213-S437 and two M6 nuts W702147-S.
3. The right hand side sits on the forward face of the existing support bracket. Reuse the fastener that you removed from the discarded portion of the dip stick tube bracket. Retain the engine fuel rail return line P15MB-03D120-A to the new transmission dip stick tube bracket P15MB-10F100-C using a P-clamp 11-054-0158, an M6 bolt W500213-S437 and a M6 nut W702147-S. Torque 8-12 Nm.

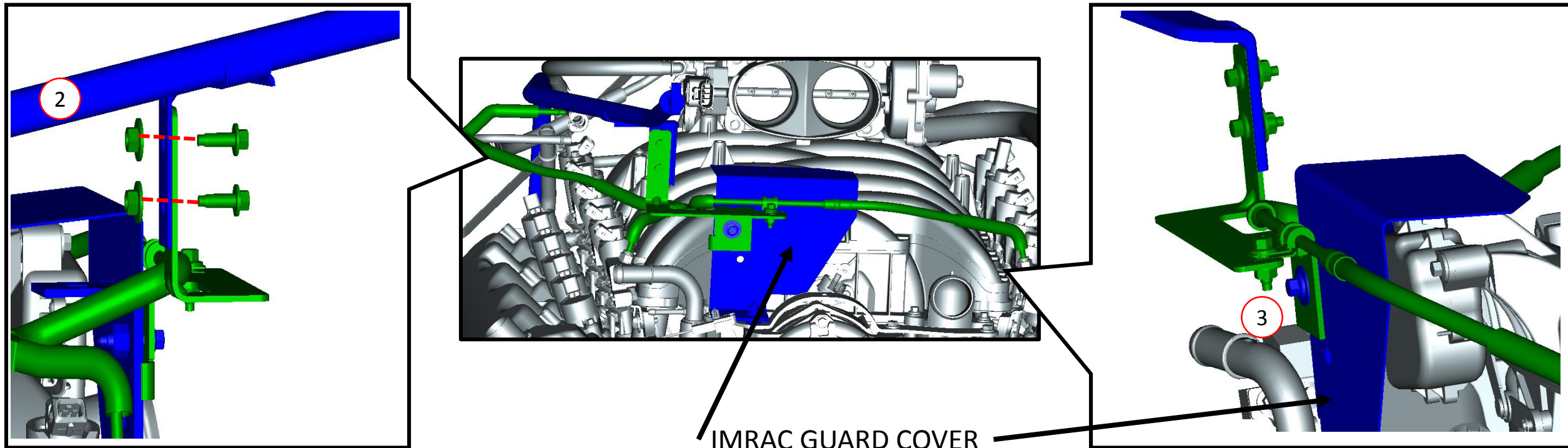

RE-INSTALLING THE TRANSMISSION VENT HOSE

1. Reattach the transmission vent hose to the engine fuel supply line using qty. 2 OEM dual C-Clips as shown below. In this view, the left side of the hose should route in front of the forward supply and return fuel lines. The right side should route behind the forward fuel lines.

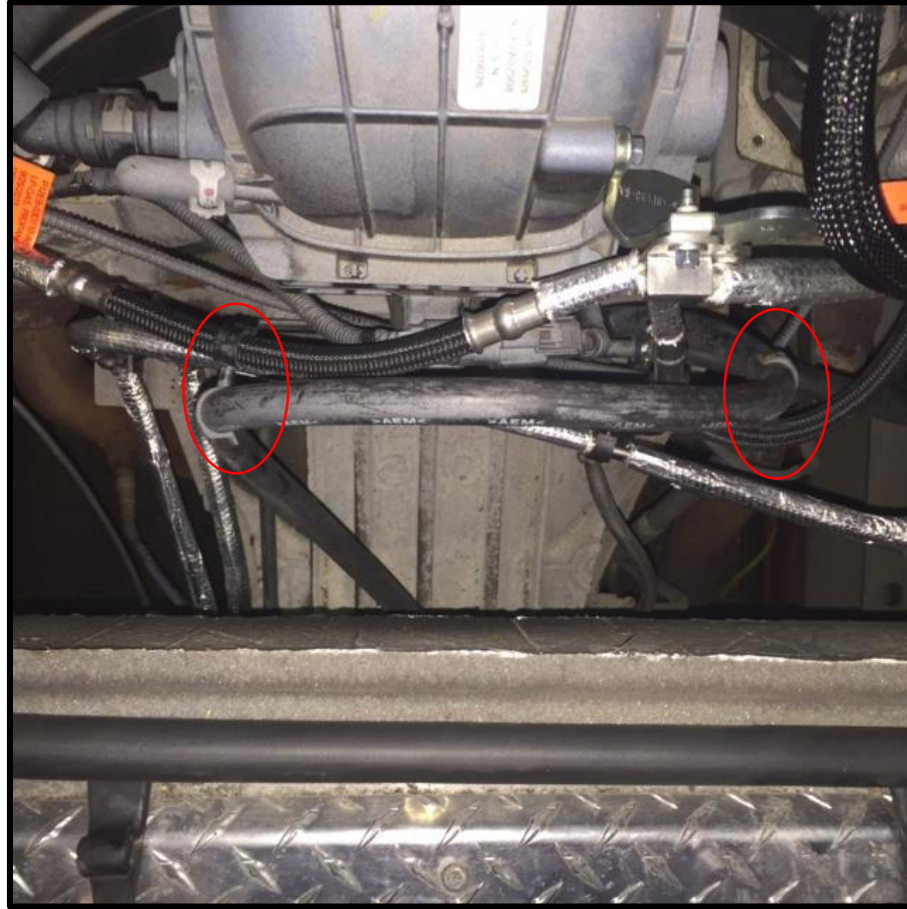

INSTALLING FUEL RAIL PRESSURE CONTROL MODULE

The following parts are found in hardware kit **P15MB-ENKIT-A**

1. Remove the OEM throttle body adapter M6 x 20 mounting bolt. Reuse this bolt to help secure the FRPCM bracket. **Figure 10.2.**
2. Position the FRPCM mounting bracket to the engine. **Figure 10.3.** Install the OEM throttle body adapter bolt, the button head bolt in the depression of the bracket and a third bolt at the rear of the bracket into the right fuel rail. Tighten bolts to 8–12 Nm.
3. Position the FRPCM to the bracket and align the four holes. **Figure 10.4.**
4. Loosely install two M6 x 16 bolts into the front bracket of the FRPCM. **Figure 10.5.**
5. Position the VMV bracket to the FRPCM inner rear hole with the tab of the bracket rearward. Loosely install two M6 x 62 bolts through the FRPCM into the FRPCM bracket. **Figure 10.6.** Tighten all four bracket bolts to 8–12 Nm.

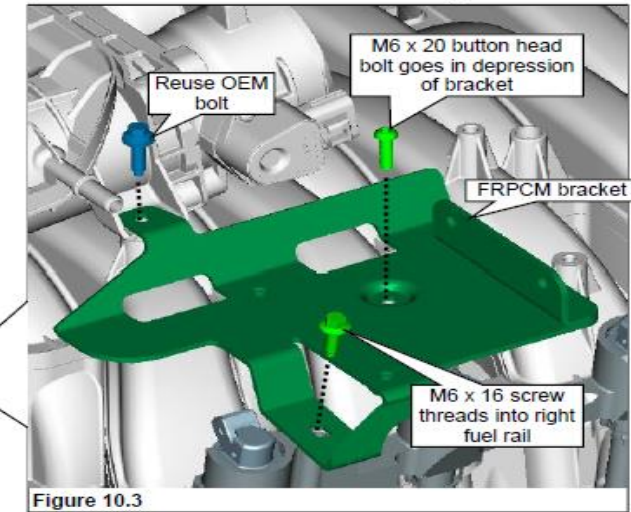
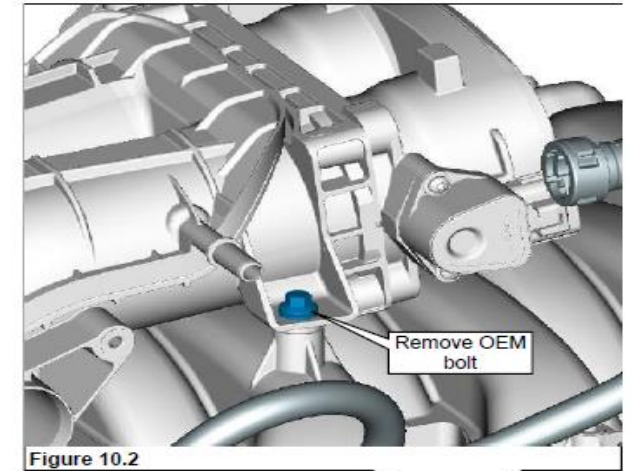
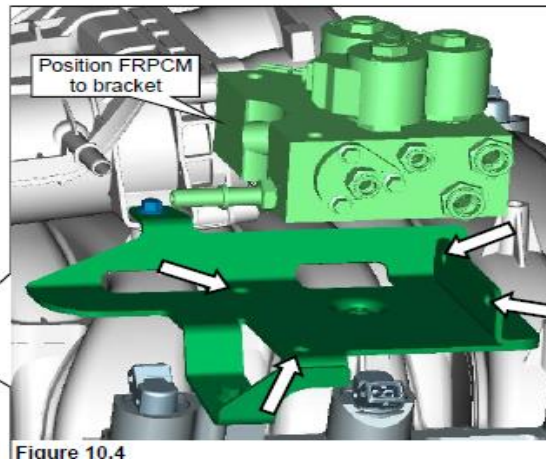
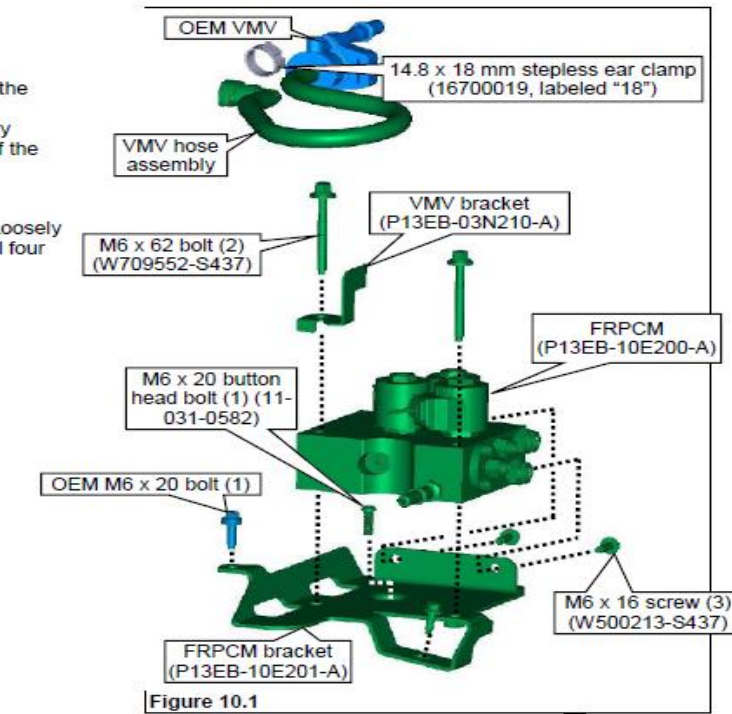
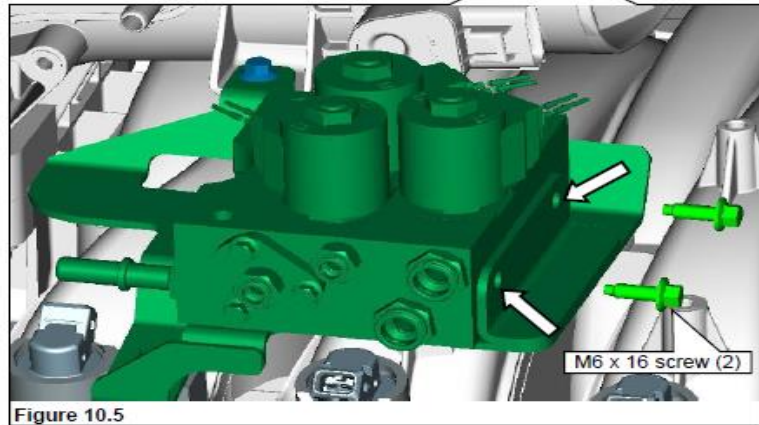
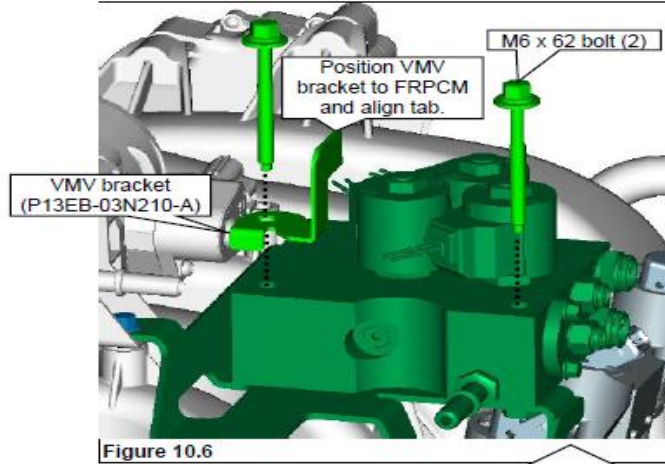

CONNECTING THE FRPCM FUEL LINES AND INSTALLING VAPOR PURGE HOSE ASSEMBLY

1. Connect each fuel line to the FRPCM as labeled below. **Figure 11.1**
2. If not completed already, slide an abrasion sleeve P11BB-10T010-A onto the purge hose assembly P13EB-03N110-A. **Figure 11.2**
3. Position the VMV with new vapor hose assembly to the bracket. Slide the VWV onto the bracket until secure. Plug the vapor hose assembly quick-connect fitting onto the port of the throttle body adaptor. Use a crimping tool to tighten the stepless ear clamp after the assembly is installed and correctly orientated. Refer to *Special Tools* for more information. Connect the OEM electrical connector to the VMV. Connect vapor hose assembly P15MB-03N100-AA to the VMV. **Figure 11.2**

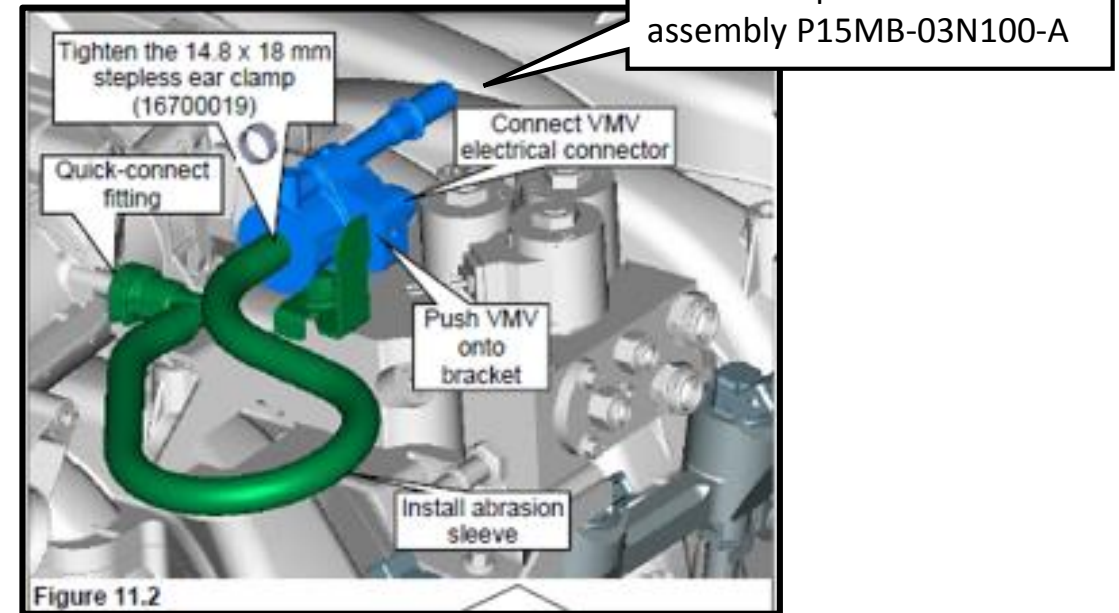
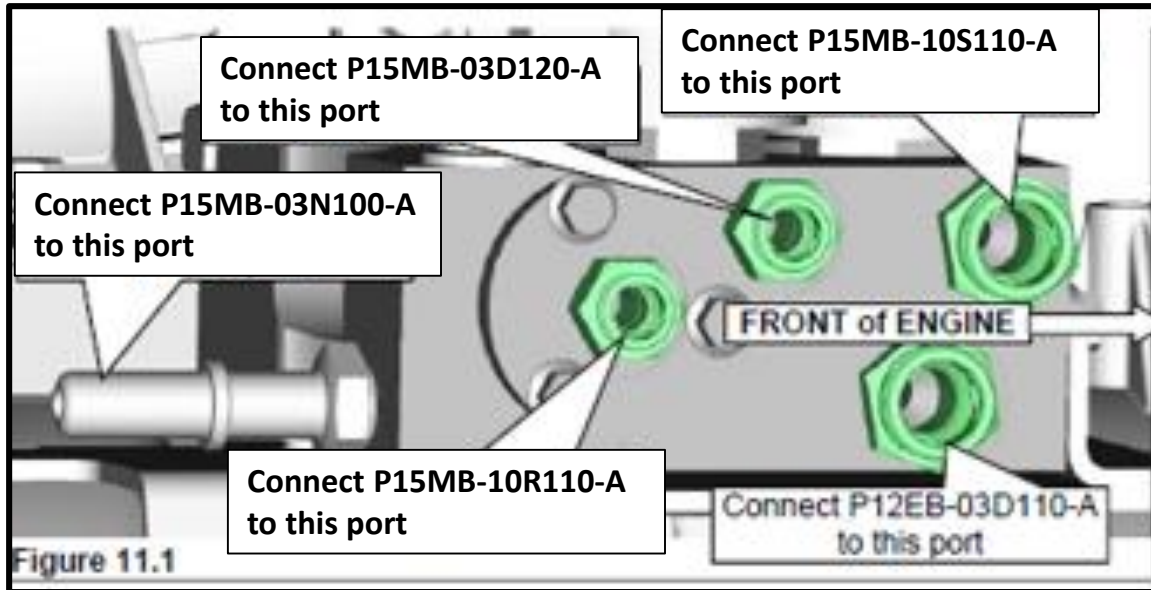

FORWARD FUEL LINES AND VAPOR HOSE RETENTION

1. Install 2 dual zip ties as shown below.
2. This dual clamp zip tie 20-403-0004 retains the vapor purge hose assembly to the engine fuel supply line. Be careful not to crush or kink the vapor line while installing the zip tie.
3. This dual clamp zip tie 20-403-0004 retains the forward supply line away from the forward return line.

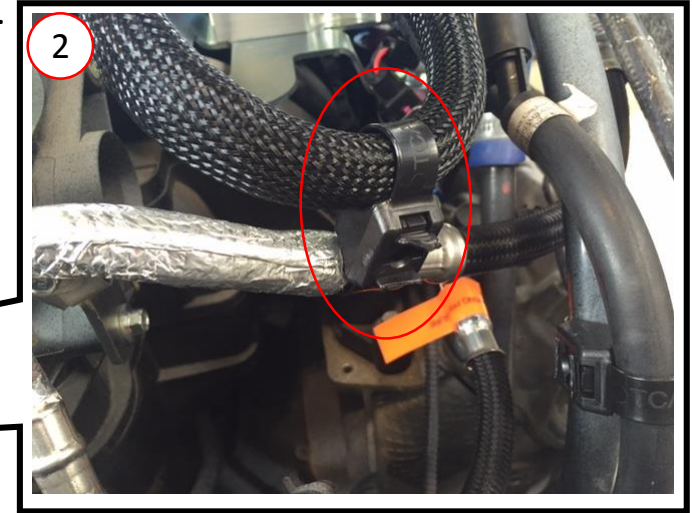

INSTALLING THE NEW PCV HOSE

1. Install the new replacement PCV hose P13FB-03H110-A as shown below. The hose routes under the transmission dip stick tube from the passenger side valve cover to the clean air intake tube

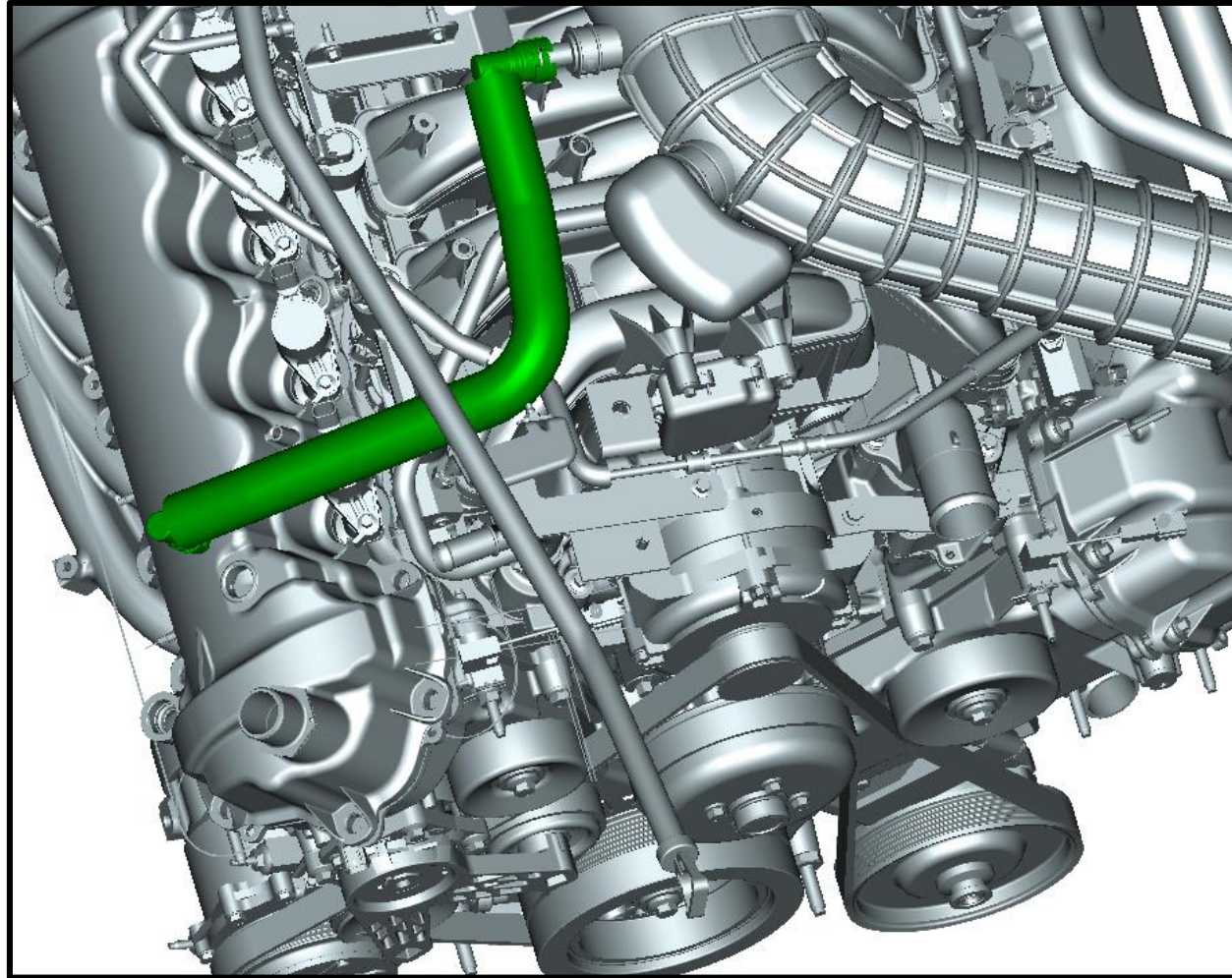

INSTALLING THE SMART RELAY MODULE (SRM)

The SRM bracket P16MB-03P211-A is installed under the hood near the brake master cylinder on the drivers side of the vehicle. See screen shot below.

1. Attach Qty. 4 J-clips 11-056-0043 to the SRM bracket P16MB-03P211-A.
2. Attach SRM bracket to body as shown reusing the existing hardware.
3. Attach SRM P14EB-03P205-A to SRM bracket using Qty. 4 M6 x 35 bolts 11-357-0310. Torque to 5-7 Nm.

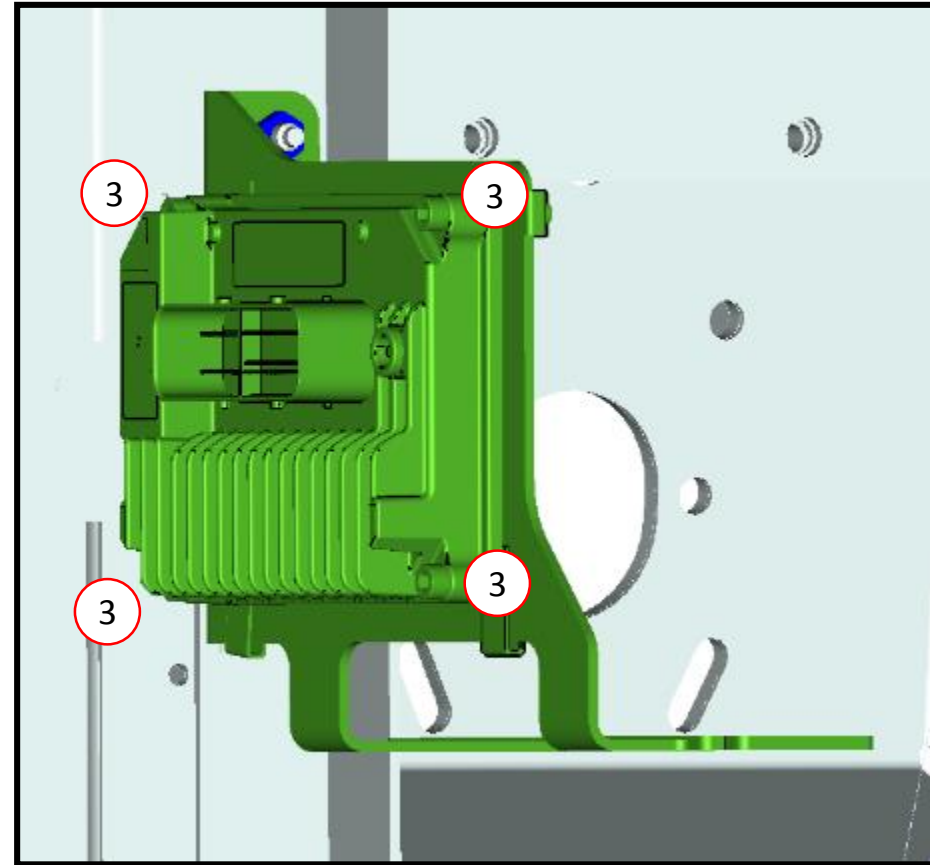
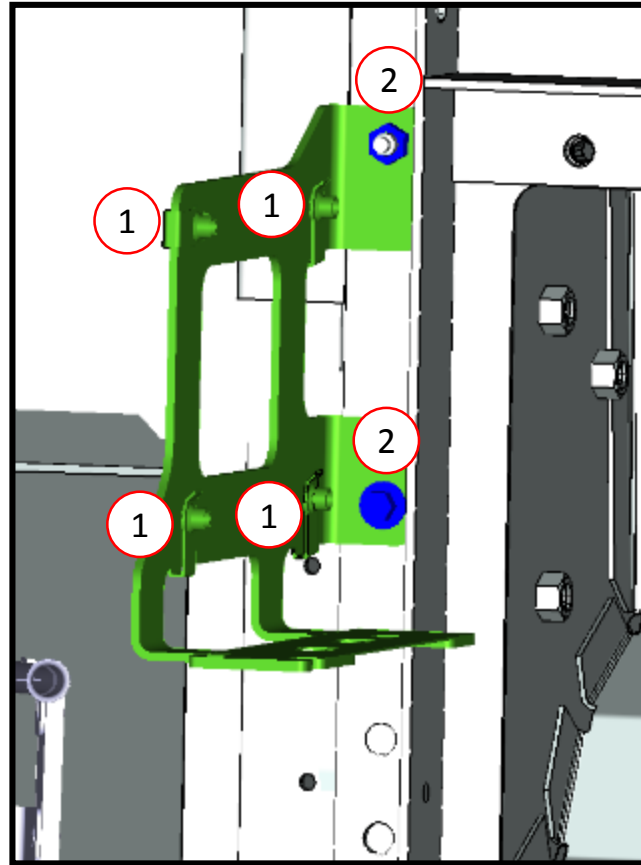
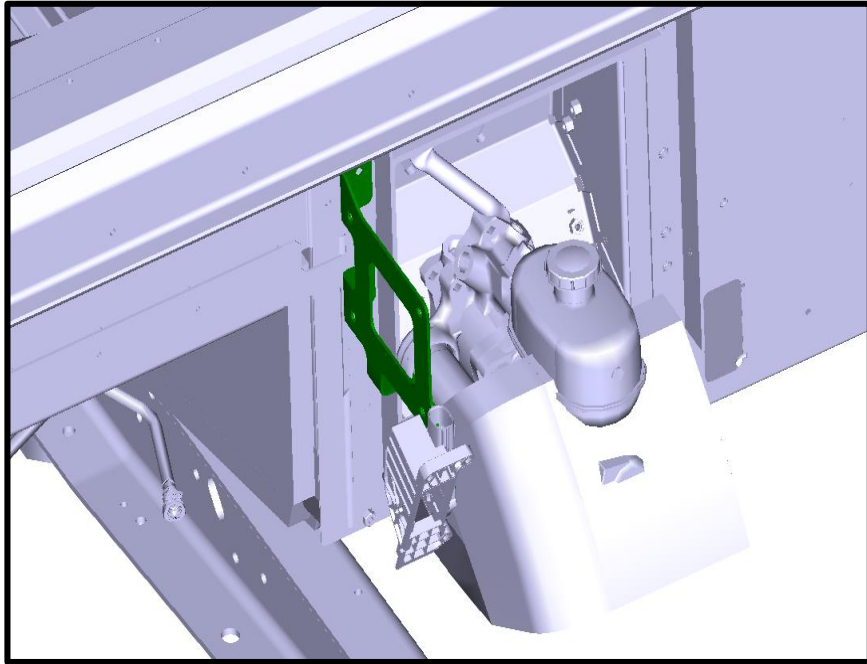

DRILLING THE FRAME FOR MOUNTING THE TANK

NOTE: THESE STEPS ARE FOR VEHICLES THAT HAVE NOT BEEN PRE-ORDERED WITH A FORD VEHICLE SPECIAL ORDER CODE. YOU MAY FIND THAT YOUR VEHICLE ALREADY HAS THE HOLES DETAILED IN THIS PAGE IN WHICH CASE YOU CAN SKIP THIS PAGE AND THE NEXT.

1. Locate the OEM reference hole in the frame. It is found approximately 880 mm (24.6 IN) behind the transmission cross member.
2. Align the supplied template P16MB-01F250-A or measure from the center of the OEM preexisting hole to determine the center of the drilling locations for the tank mounting fasteners.

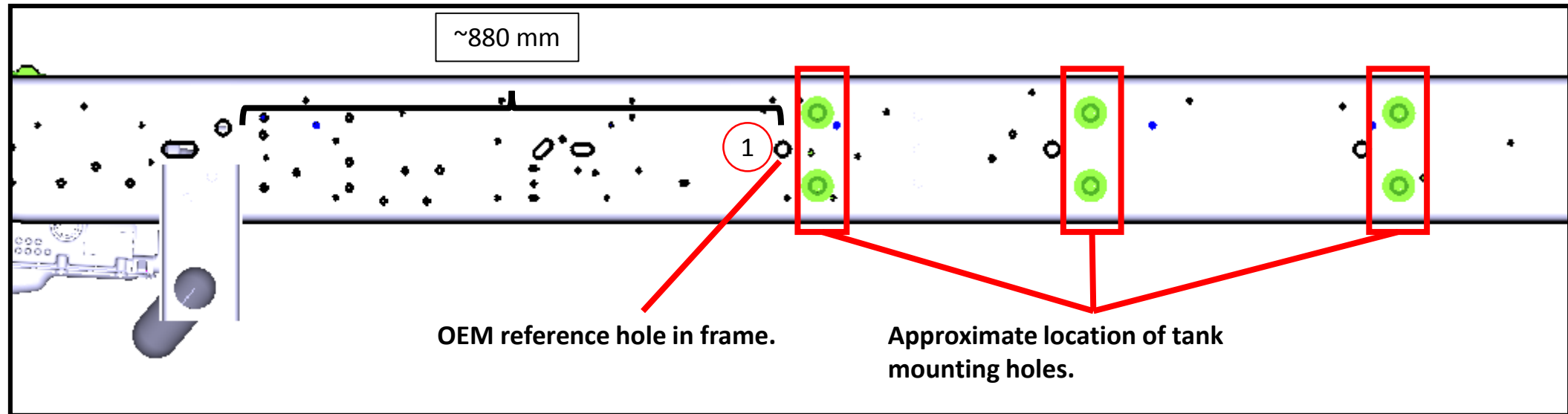

DRILLING THE FRAME FOR MOUNTING THE TANK (CONTINUED)

3. Mark the locations using a center punch or marking gauge.
4. Drill small pilot holes in each of the six (6) fuel tank mounting locations using a 1/8" drill bit.
5. Using a step bit or gradually increasing bit size, drill all tank mounting holes to 5/8" (16 mm).
6. Deburr and coat all bare metal using a premium undercoating. Refer to the *Special Tools section*.

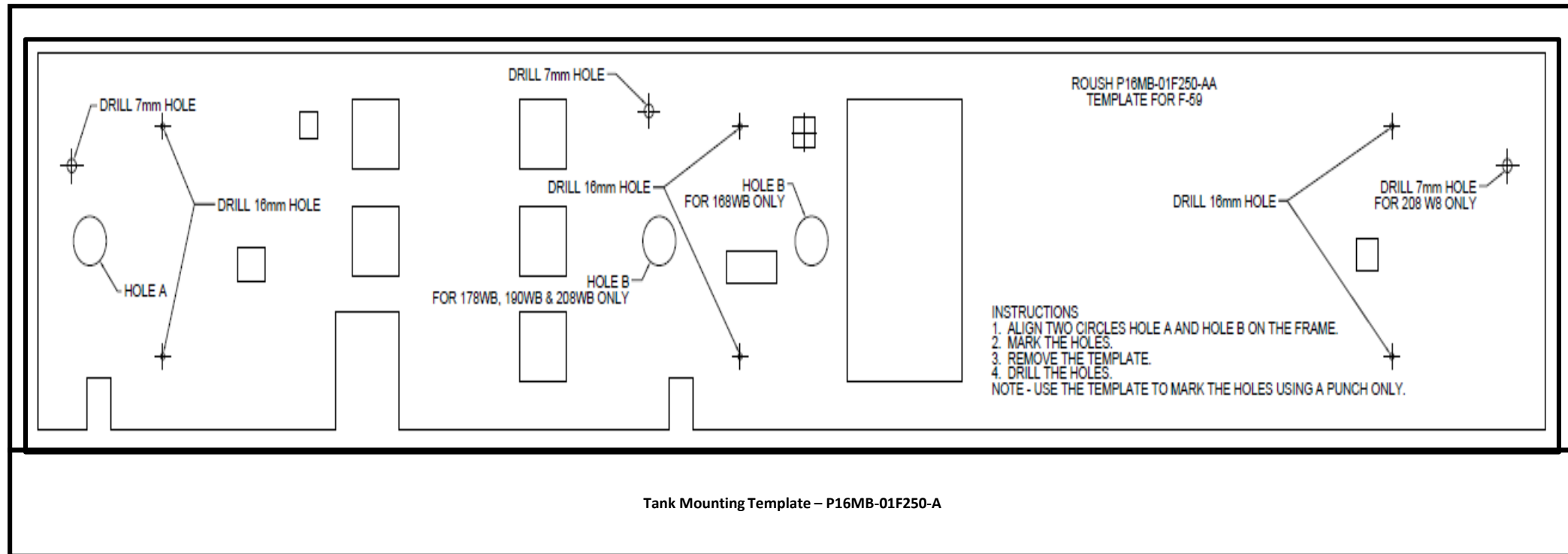

DRILLING ADDITIONAL HOLES (208" WHEELBASE ONLY)

NOTE: THESE STEPS ARE FOR 208" WHEELBASE VEHICLES THAT HAVE NOT BEEN PRE-ORDERED WITH A FORD VEHICLE SPECIAL ORDER CODE. YOU MAY FIND THAT YOUR VEHICLE ALREADY HAS THE HOLES DETAILED IN THIS PAGE IN WHICH CASE YOU CAN SKIP THIS PAGE AND THE NEXT.

1. Locate the OEM fuel line retention bracket closest to the rear propane tank mounting holes.
2. On the outside of the frame, measure and mark a point 127 mm (5 in) towards the rear of the fuel line retention bracket bolt.
3. Drill a hole through the marked point using a 7 mm (or a size I or J) drill bit.
4. Deburr and coat all bare metal using a premium undercoating. Refer to the *Special Tools* section.
5. Remove the bolt and nut from the OEM fuel line retention bracket but leave the bracket on the lines.
6. Slide the bracket back and attach it to the new hole using the same hardware. Torque to 8-12 Nm.

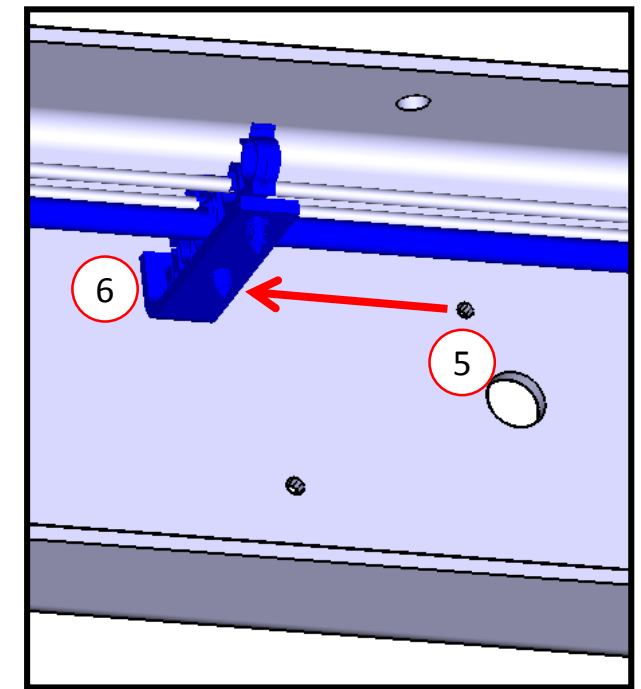
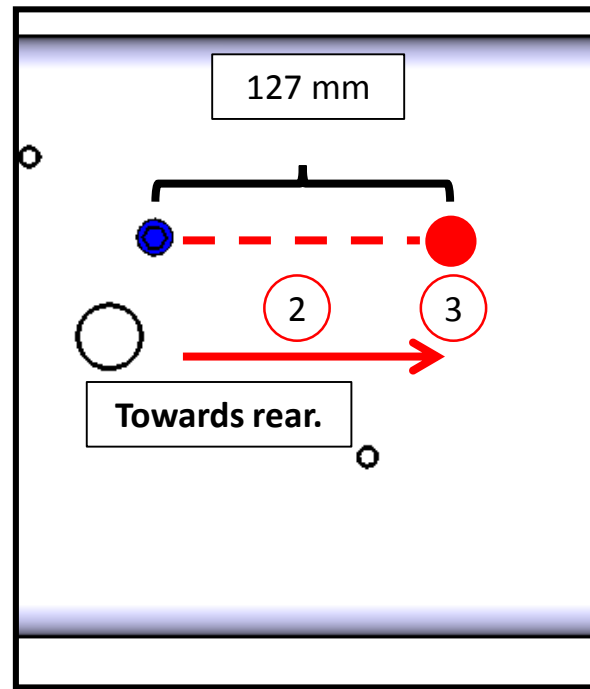
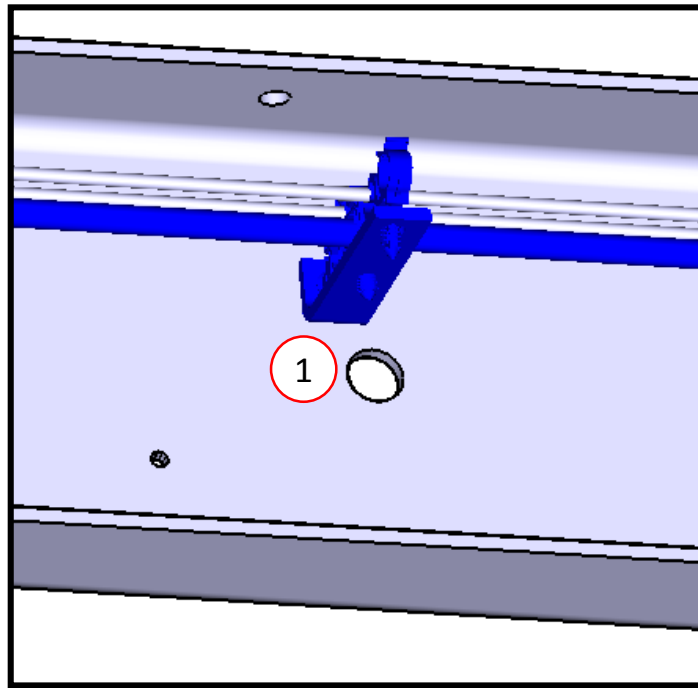

DRILLING ADDITIONAL HOLES CONT. (208" WHEELBASE ONLY)

NOTE: THESE STEPS ARE FOR VEHICLES THAT HAVE NOT BEEN PRE-ORDERED WITH A FORD VEHICLE SPECIAL ORDER CODE. YOU MAY FIND THAT YOUR VEHICLE ALREADY HAS THE HOLES DETAILED IN THIS PAGE IN WHICH CASE YOU CAN SKIP TO THE NEXT PAGE.

1. Locate the OEM fuel line retention bracket closest to the front propane tank mounting holes.
2. On the outside of the frame, measure and mark a point 101.6 mm (4 in) towards the front of the fuel line retention bracket bolt.
3. Drill a hole through the marked point using a 7 mm (or a size I or J) drill bit.
4. Deburr and coat all bare metal using a premium undercoating. Refer to the *Special Tools* section.
5. Remove the bolt and nut from the OEM fuel line retention bracket but leave the bracket on the lines.
6. Slide the bracket forward and attach it to the new hole using the same hardware. Torque to 8-12 Nm.

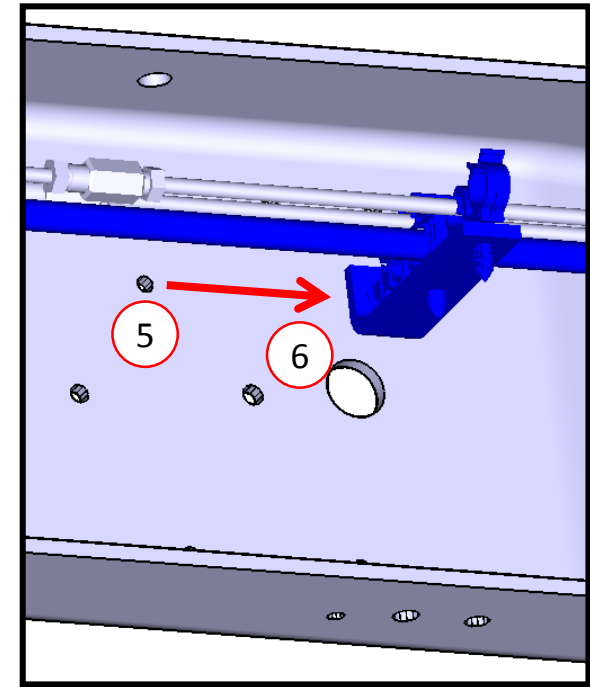
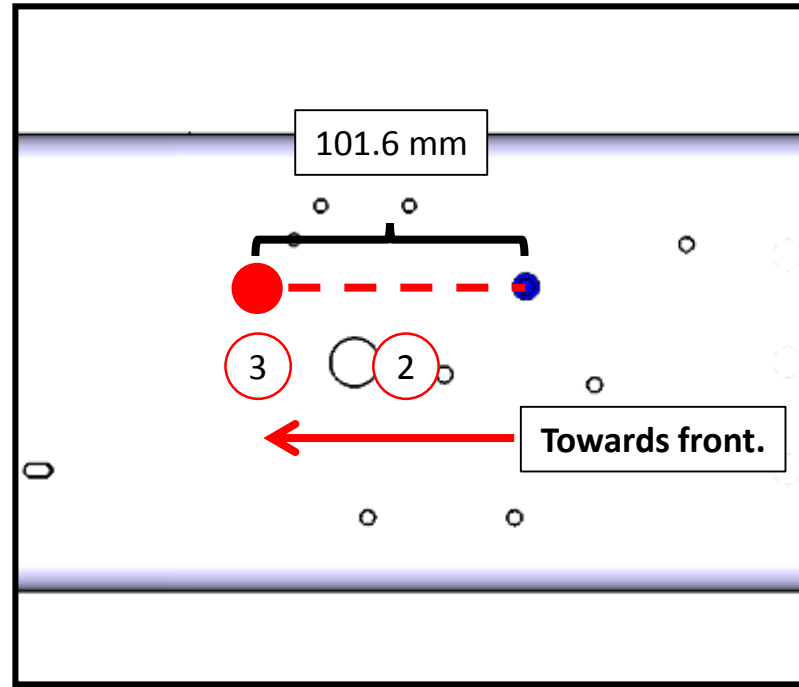
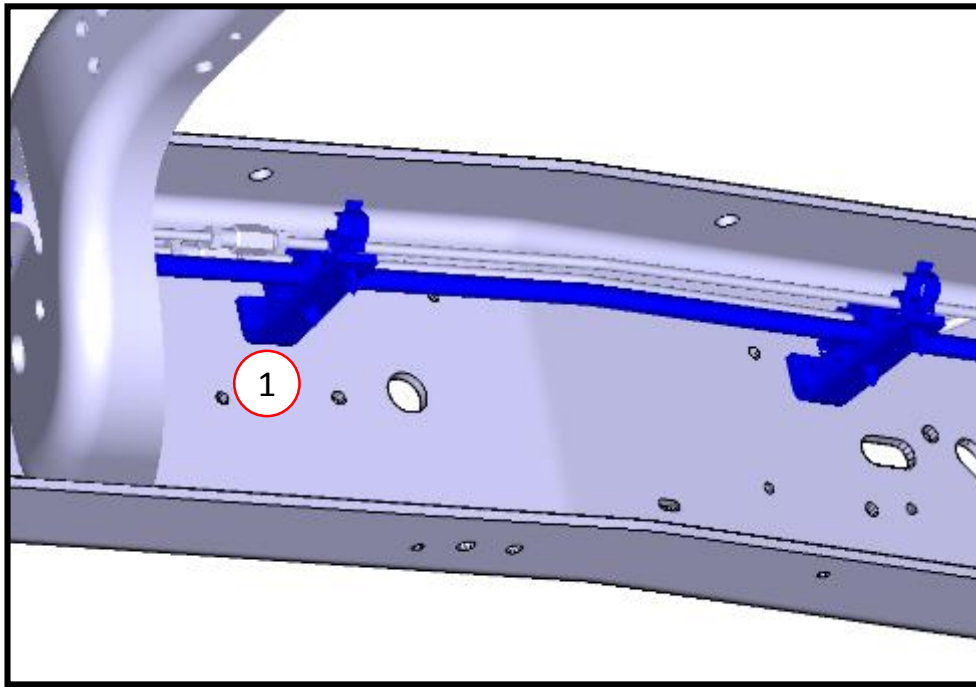

DRILLING ADDITIONAL HOLES CONT. (178", 190" AND 208" WHEELBASE ONLY)

NOTE: THESE STEPS ARE FOR 178", 190", AND 208" WHEELBASE VEHICLES THAT HAVE NOT BEEN PRE-ORDERED WITH A FORD VEHICLE SPECIAL ORDER CODE. YOU MAY FIND THAT YOUR VEHICLE ALREADY HAS THE HOLES DETAILED IN THIS PAGE IN WHICH CASE YOU CAN SKIP TO THE NEXT PAGE.

1. Locate the OEM reference hole detailed in the "DRILLING THE FRAME FOR MOUNTING THE TANK" section.
2. Locate the next OEM pre-existing hole of the same size which is located 440 mm (17.3 in) rear of the OEM reference hole.
3. On the outside of the frame, measure and mark a point 8 mm (0.3 in) forward and 67 mm (2.6 in) above the centerline of the hole identified in Step 2.
4. Drill a hole through the marked point using a 7 mm (or a size I or J) drill bit.
5. Deburr and coat all bare metal using a premium undercoating. Refer to the *Special Tools* section.
6. Install a two double snail clips 15-004175 on the fuel line retention bracket P15MB-10F100-B as shown.
7. Locate the fuel line bracket by lining it up with the hole.
8. Attach using a M6 x 20 bolt W500214-S437 and M6 nut 11-278-0274. Torque to 8-12 Nm.

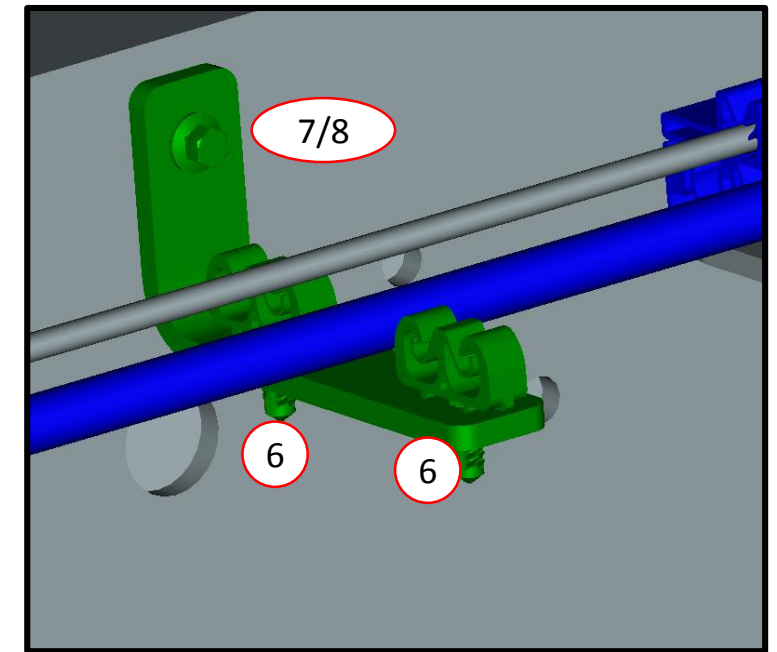
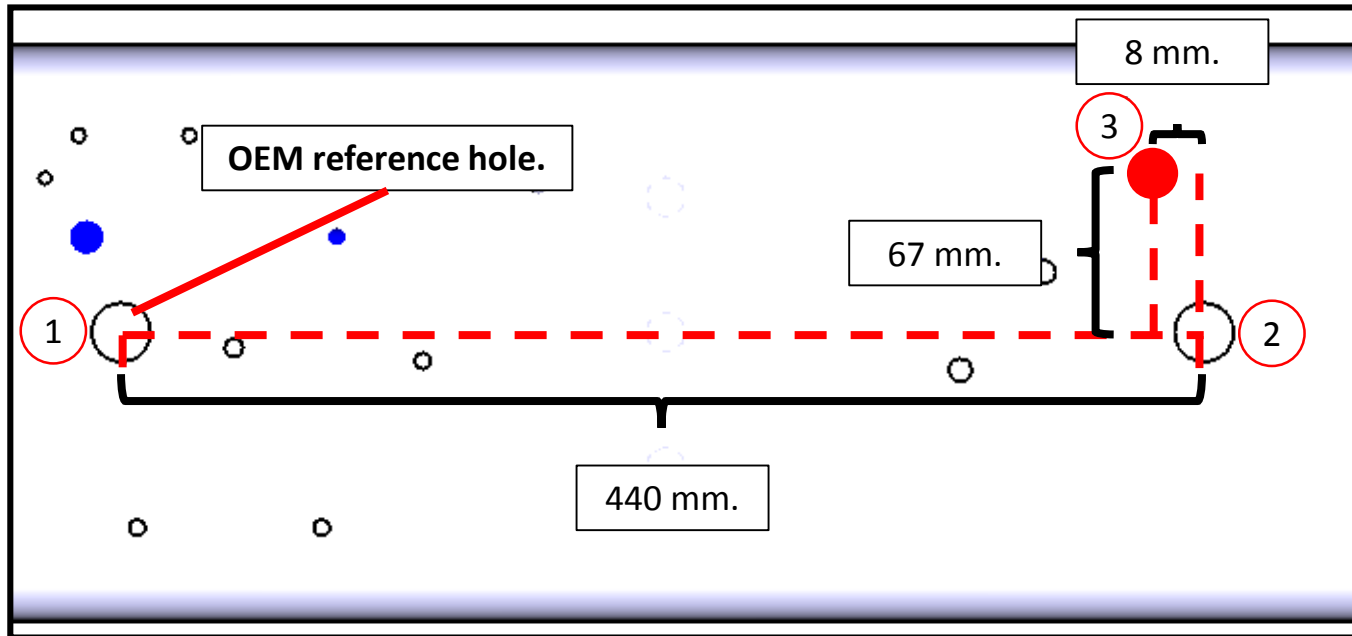

ASSEMBLING THE FILL FILTER

1. Assemble the fill filter P11BB-9155-A to the fill filter bracket P11GD-10D220-B using a worm gear clamp 6P-300-52. Make sure that the fuel flow direction on the filter is oriented correctly as shown below. Tighten the clamp to secure the filter to the bracket.

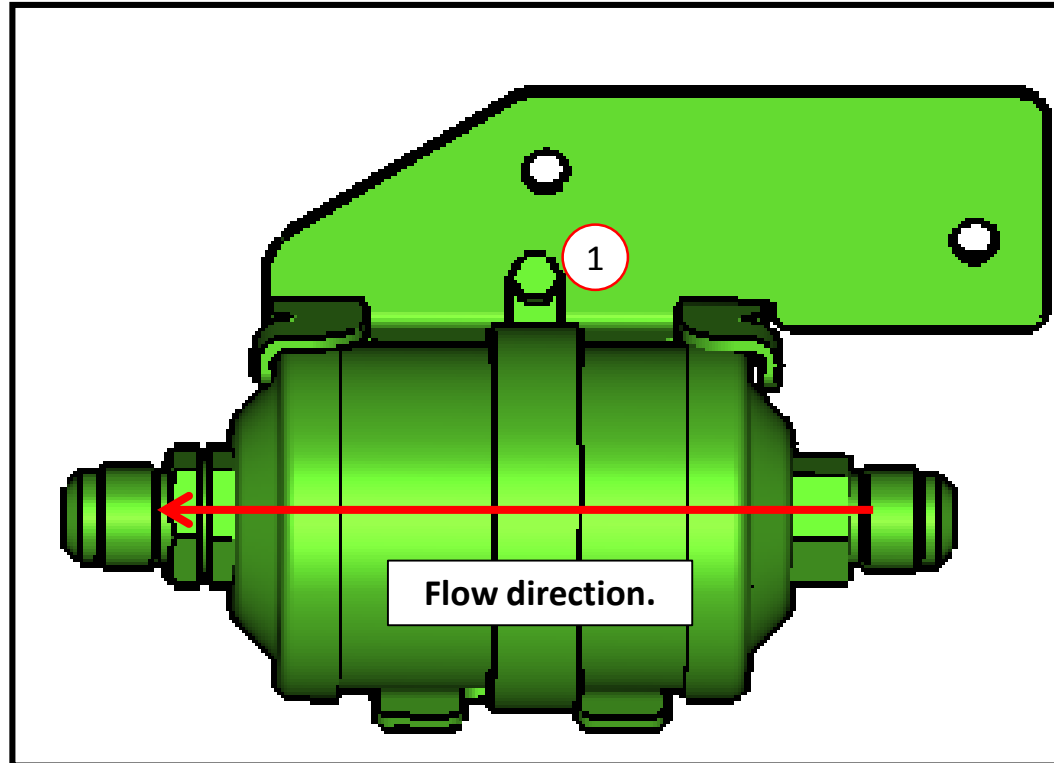

INSTALLING THE FILL SYSTEM – FILL FILTER

1. Install the Qty. 2 J-clips W520822-S439 to the fill filter bracket mount on the fuel tank.
2. Position the fill filter bracket assembly as shown and attach using Qty. 2 M6 x 16 bolts W500213-S437 Torque to 8-12 Nm.
3. Verify that the fuel flow direction arrows on the filter are pointing towards the front of the vehicle, if this is not the case then loosen the worm clamp and turn the filter around.
4. Attach the fill hose P-10D121-C-240 to the tank and filter as shown below. The 90 degree elbow should go to the tank.
5. Torque the fittings to 41-49 Nm. **Use two wrenches when tightening the filter side.**

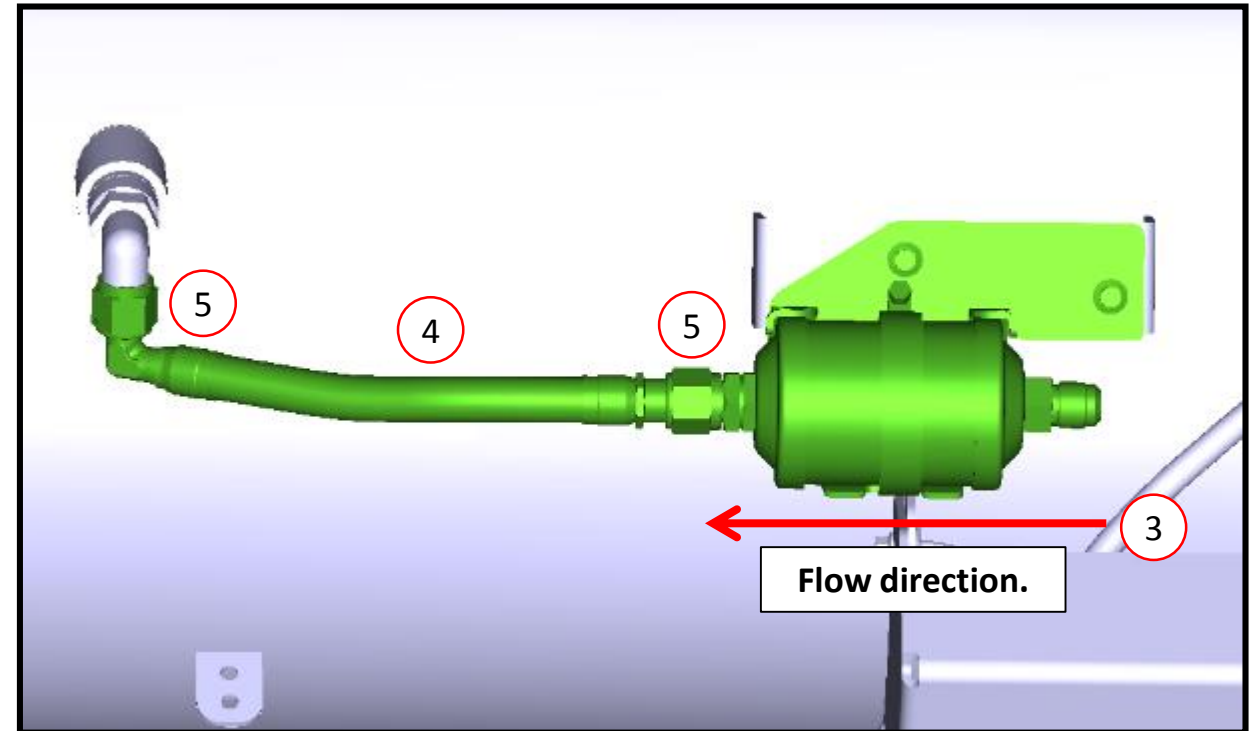
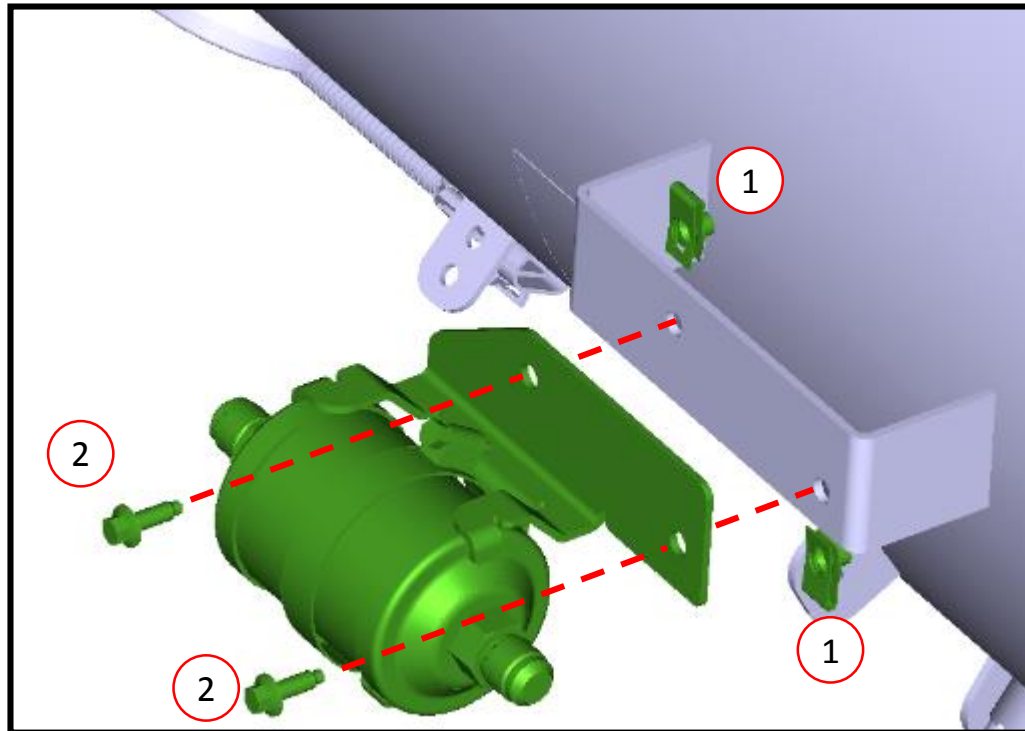

PREPARING THE TANK

1. Install Qty. 5 double snail clips 15-004175 onto the tank on the two mounting brackets closest to the tank access hole.

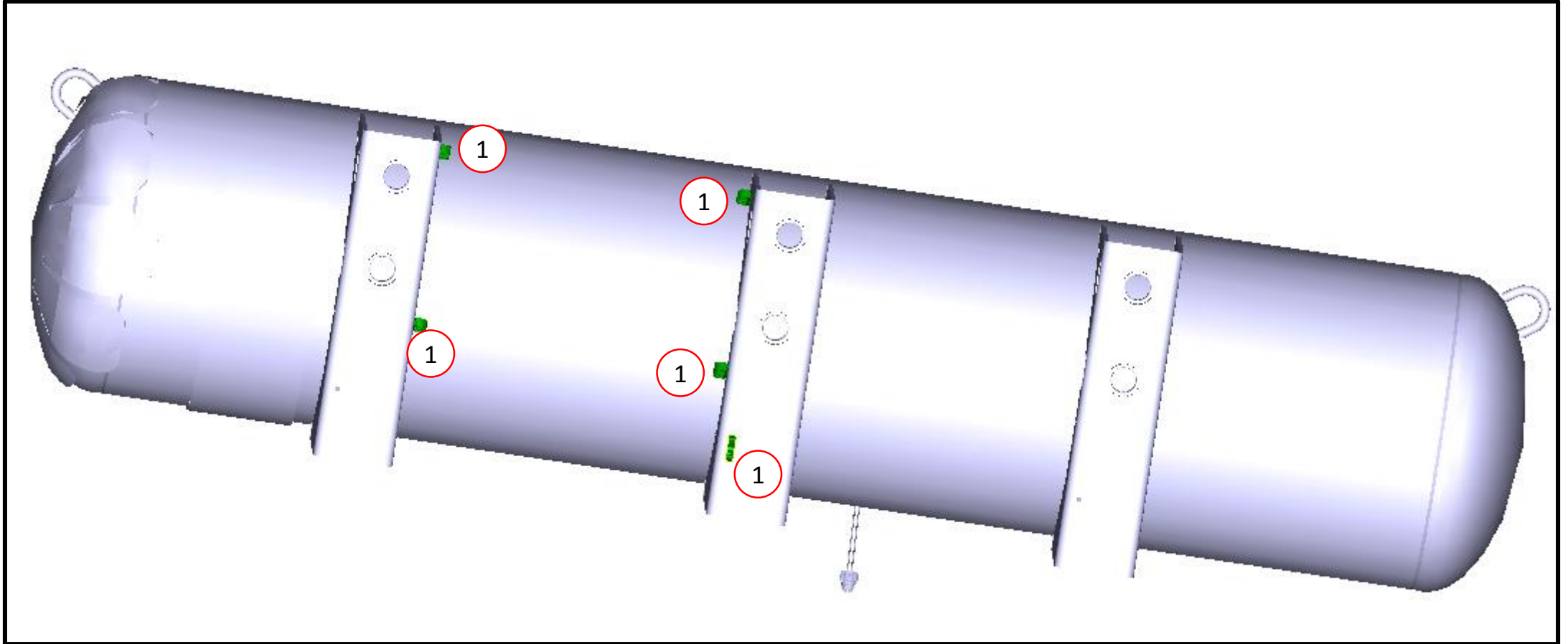

INSTALLING THE TANK

1. Assemble the 6 isolators and 6 crush limiters as shown onto the tank mounting brackets. **NOTE THE CORRECT ORIENTATION OF THE COMPONENTS.**
2. Use a suitable lifting device and position the fuel tank to the left frame rail. Align the six mounting holes in the tank brackets with the mounting holes in the frame rail.
3. Carefully position the tank assembly to the frame rail until the tank (and hardware) is aligned with frame mounting holes.
4. Place the three doubler plates P14MB-02G001-A in position against the inside of the frame rail. Install the M12 x 1.75 x 100 mm bolts through the holes in the doubler plate. Slip the washers into position between the frame and mounting isolator. Continue installing the bolts through the holes in the tank mounting brackets.
5. Install the six M12 x 1.75 mounting nuts and corresponding washers, one each onto the M12 bolts. Thread the nuts onto the bolts hand tight. Tighten the fasteners to 80-90 Nm.

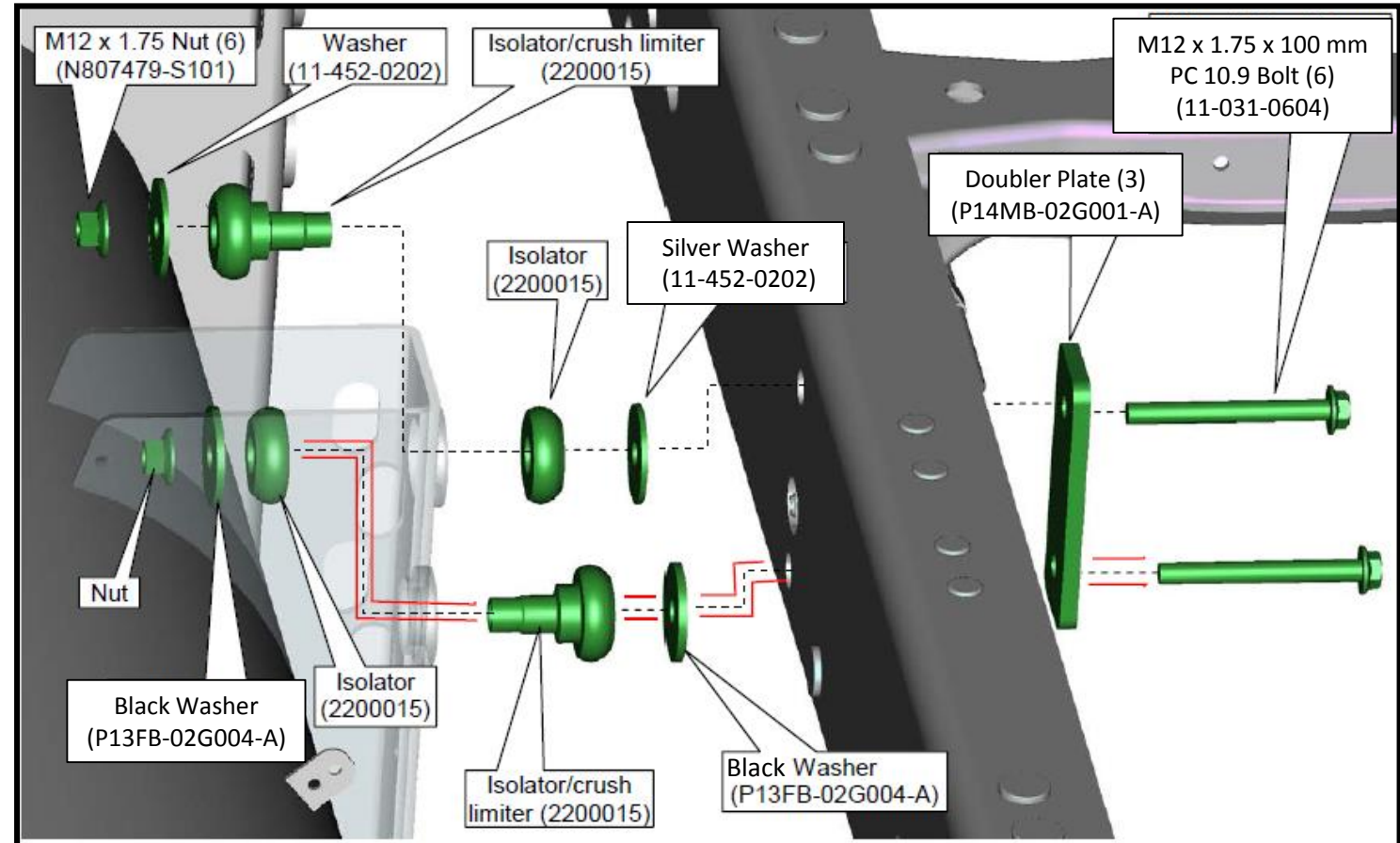

Black

INSTALLING THE INTERMEDIATE SUPPLY LINE

1. Install a double snail clip 15-004175 onto the OEM fuel line retention bracket that is in front of the ABS module as shown.
2. Install the intermediate fuel supply line P15MB-10S120-A as shown below. Clip the line into the two double snail clips and the four existing Ford OEM retention clips.
3. Connect the forward supply line to the intermediate supply line.

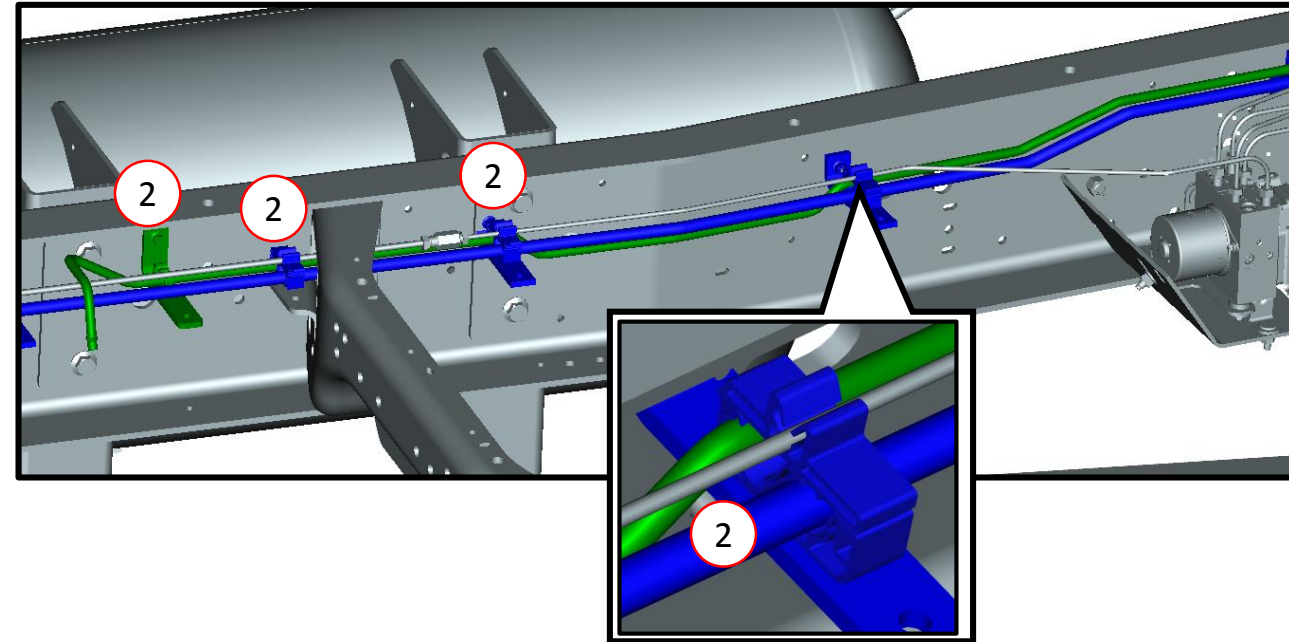
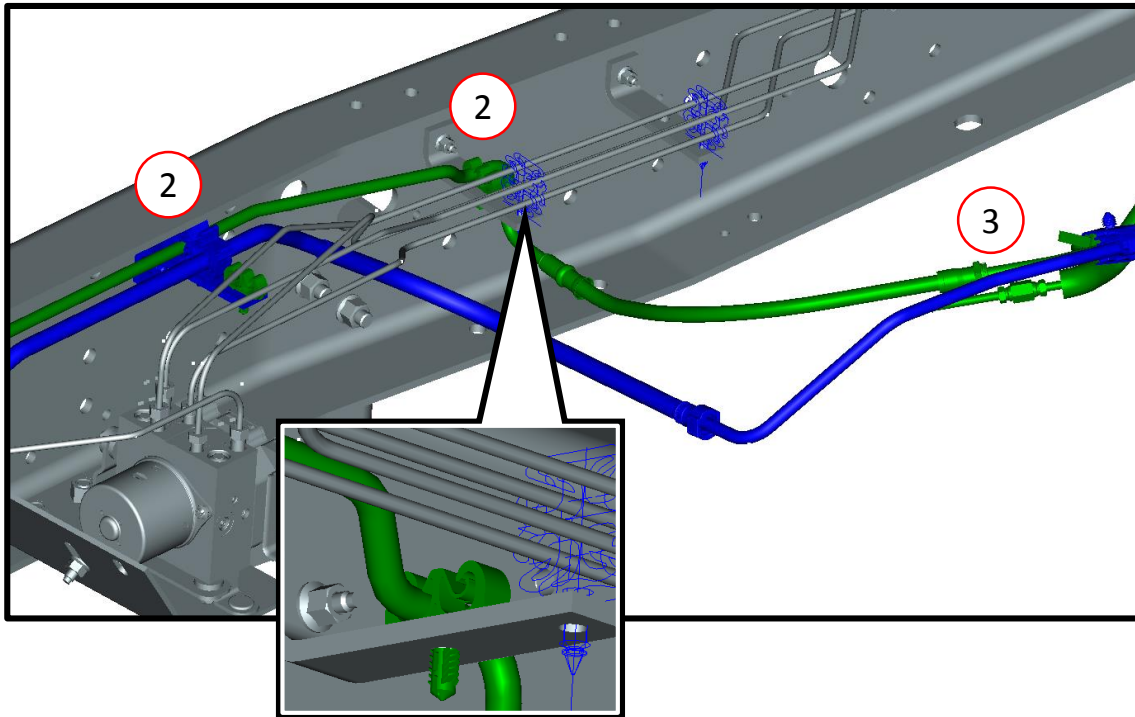

INSTALLING THE INTERMEDIATE RETURN LINE

1. Install 4 double snail clips 15-004175 onto the OEM fuel line retention brackets as shown.
2. Install the intermediate fuel supply line P16MB-10R120-A as shown below. Make sure to clip the line into the double snail clips and into the corresponding OEM retention clips.
3. Connect the forward return line to the intermediate return line.

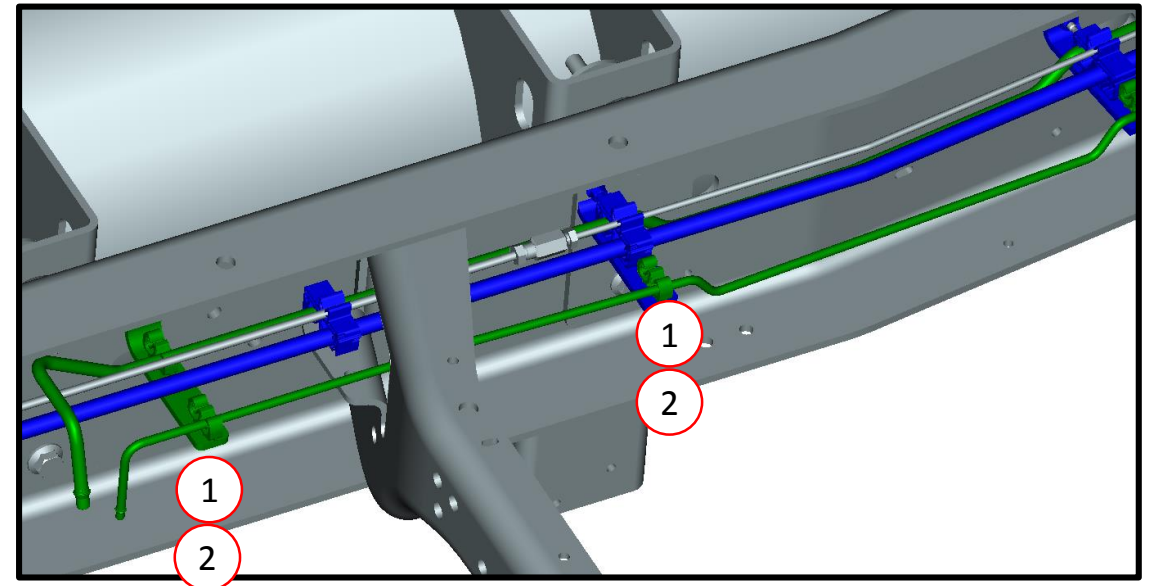
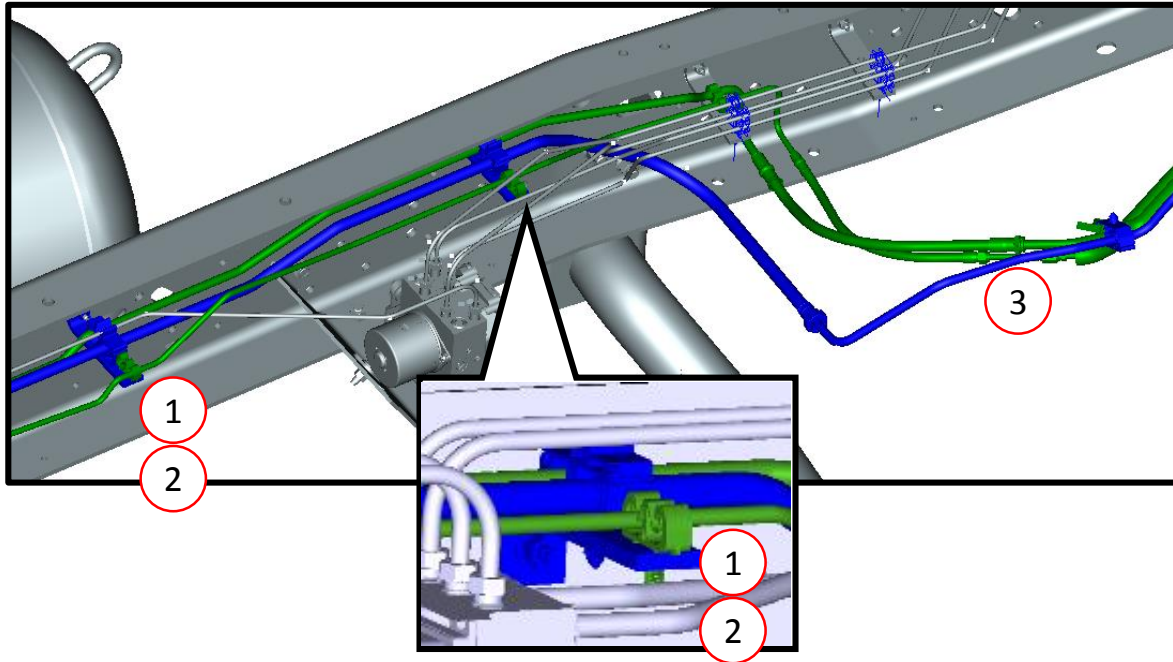

INSTALLING THE REAR RETURN LINE

1. Install the rear supply line P15MB-10R130-A between the tank and frame as shown below.
2. Clip the return line into the snail clips on the tank at two locations as shown.
3. Connect the rear tank return line to the intermediate return line.

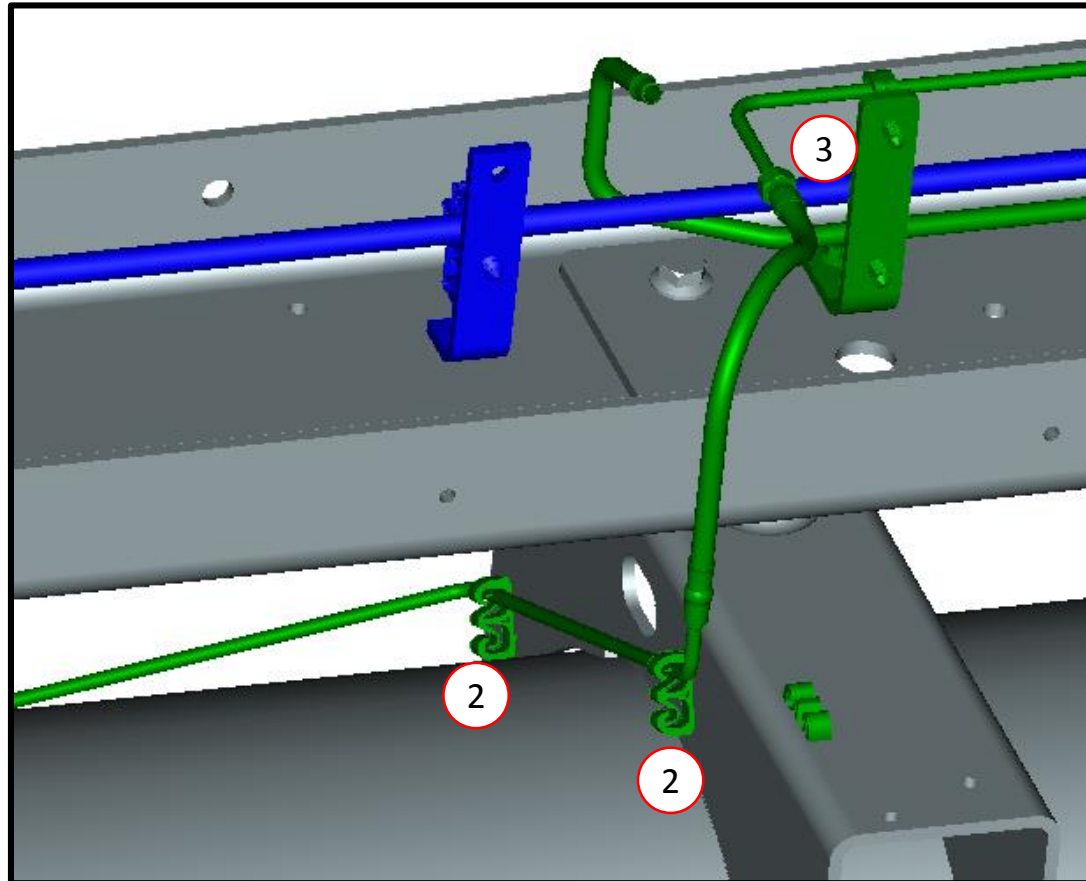

INSTALLING THE REAR SUPPLY LINE

1. Install the rear supply line P15MB-10S130-A between the tank and frame as shown below.
2. Clip the supply line into the 3 snail clips 15-004175 on the tank as shown.
3. Connect the rear supply line to the intermediate supply line.

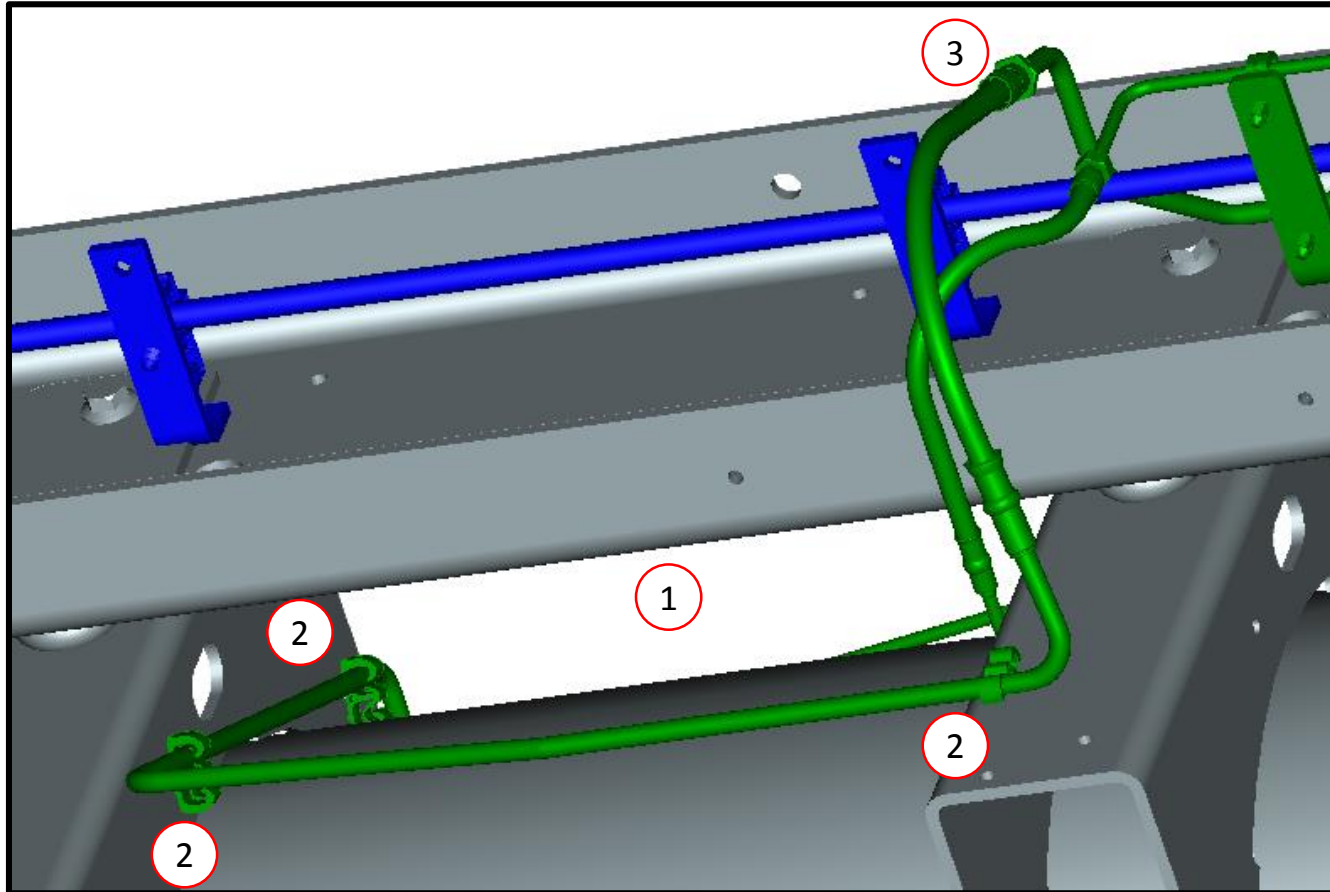

CONNECTING THE SUPPLY AND RETURN VALVES TO THE REAR LINES

1. Attach supply line to supply valve.
2. Attach return line to return valve.
3. Attach a dual clamp zip tie 20-403-0004 to both fuel lines as shown below.
4. Retain the dual clamp zip tie to the tank using an M6 bolt 92095A250 and M6 nut 11-278-0274. Torque to 8-12 Nm.
5. Add a snail clip as shown below to retain return line to supply line on the top side of the fuel tank.

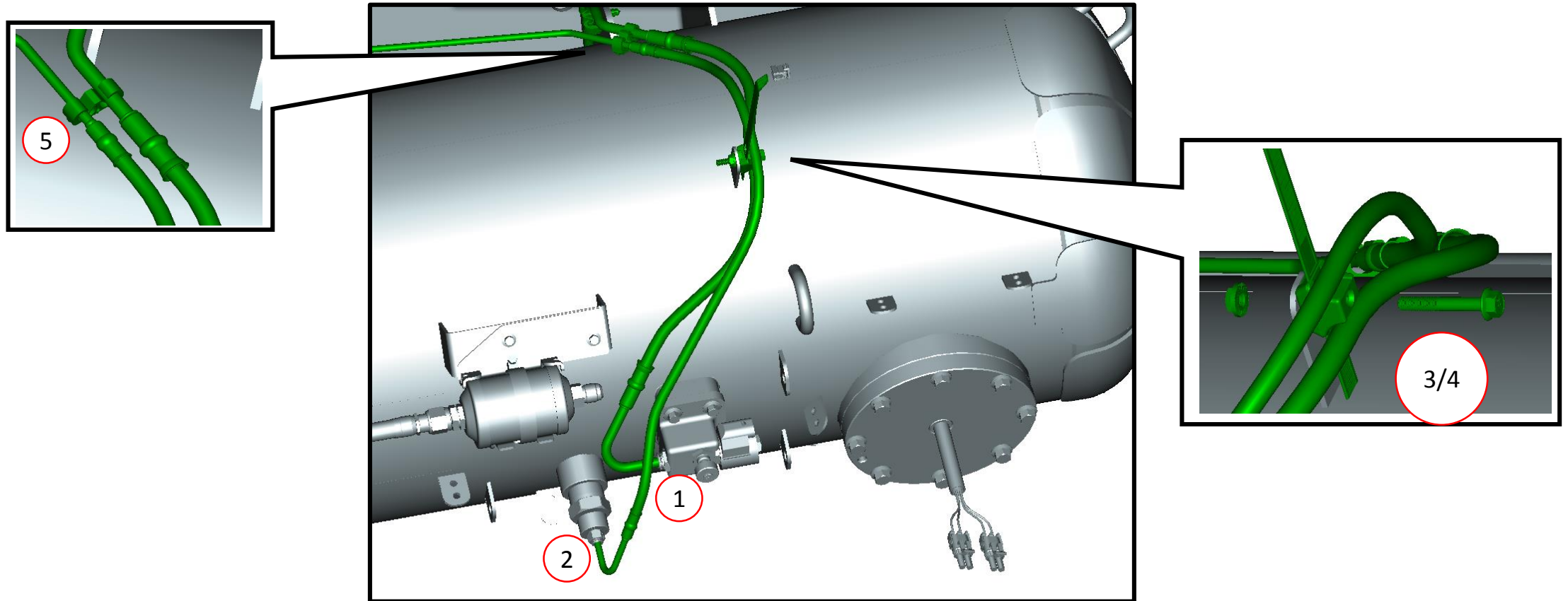

ASSEMBLING THE FILL VALVE (EURO VALVE)

NOTE: THESE STEPS ARE FOR THE EURO FILL VALVE (Quick-Connect Style) ONLY. IF YOUR VEHICLE HAS THE ACME VALVE (Threaded Style) THEN PLEASE SKIP TO THE NEXT PAGE.

1. Attach Qty. 4 M5 J-clips 95210A130 to the Euro valve bracket P16MB-10D310-A.
2. Attach the Euro valve 22-4945 to the bracket using Qty. 4 M5x0.8x16 countersunk socket cap screws. Torque the bolts to 5-7 Nm.
3. Attach the straight end of fill hose P-10D124-C-4724 to the fill valve mounted to the body. Torque the fitting on the fill valve to 41-49 Nm.

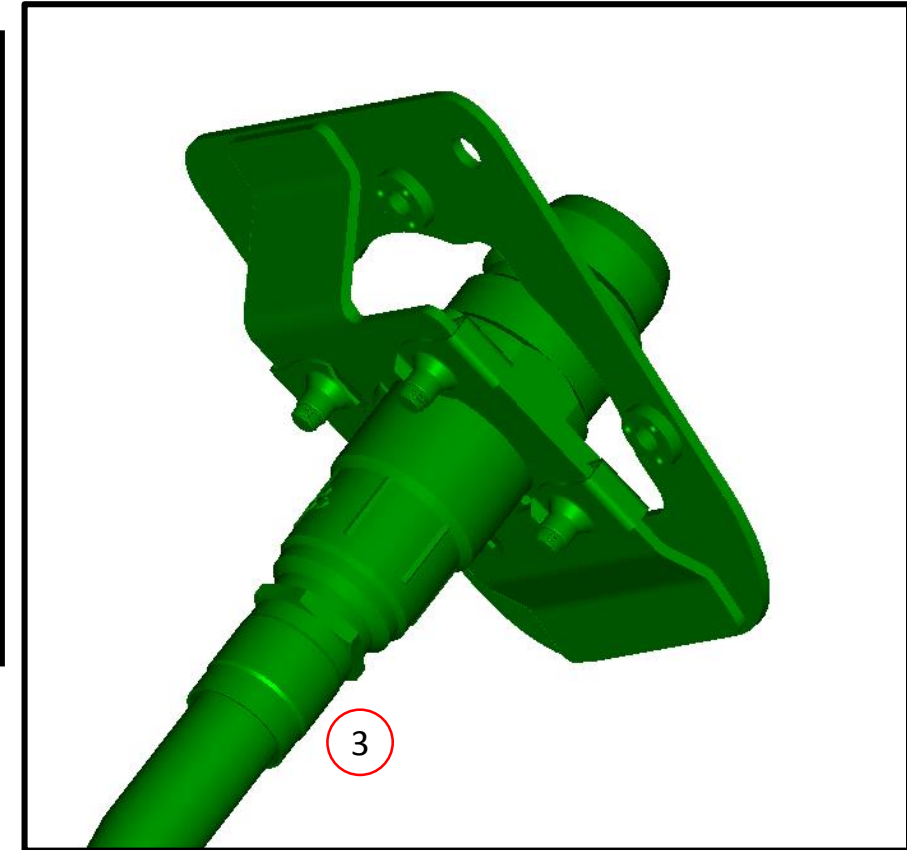
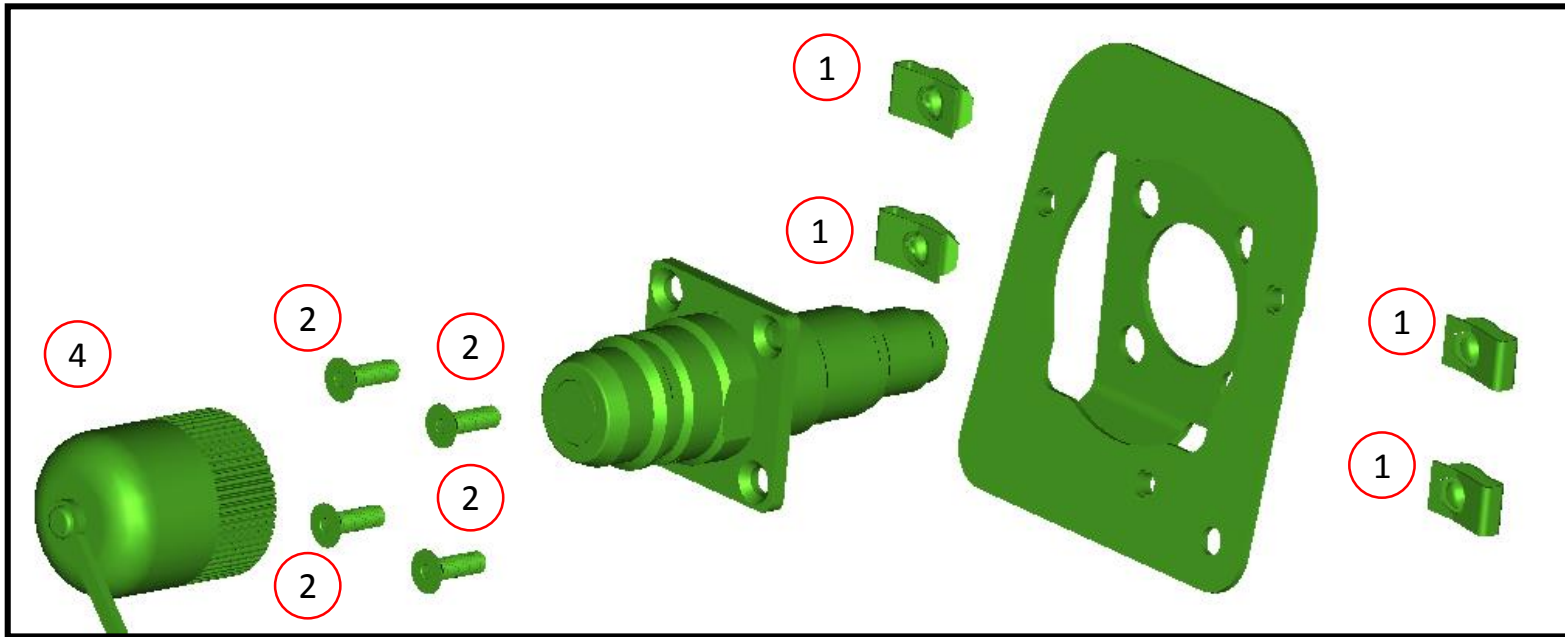

ASSEMBLING THE FILL VALVE (ACME VALVE)

1. Remove nut and washer from fuel fill valve 11-438-005 and assemble valve to fuel fill bracket (P10C2-9B213-A).
2. Support fill valve and bracket assembly and tighten nut securely.



INSTALLING THE FILL SYSTEM

1. Install the fuel fill hose as shown. Follow the gasoline fill tube routing where the hose routes from the fill valve to the frame. Then feed along the top of the frame rail and tank.
2. Attach the 45 degree end of the fill line P-10D124-C-4724 to the fill filter. Torque the fitting to 41-49 Nm.
3. Attach 7 P-clip's 11-056-0042 along the fill hose in the locations shown below.

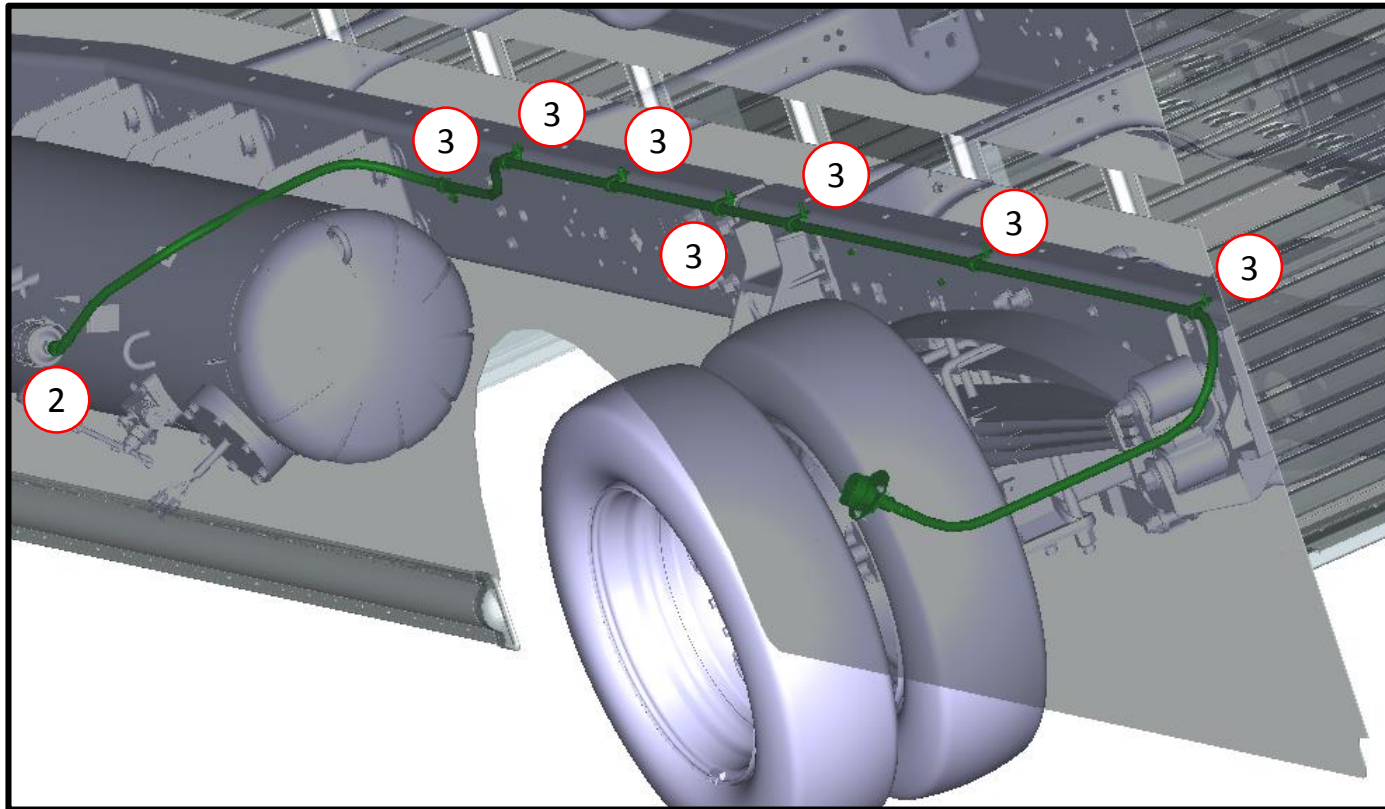

INSTALLING THE FILL SYSTEM CONT.

5. The P-clamp that is closest to the tank mounts to the frame rail and the 3 others shown below mount to the cargo floor. The mounting locations utilize existing holes in the frame and cargo floor. Each of the 4 P-clamps is installed using an M6 x 20mm bolt 98093A440 and an M6 nut W702147-S438. Torque 8-12 Nm.

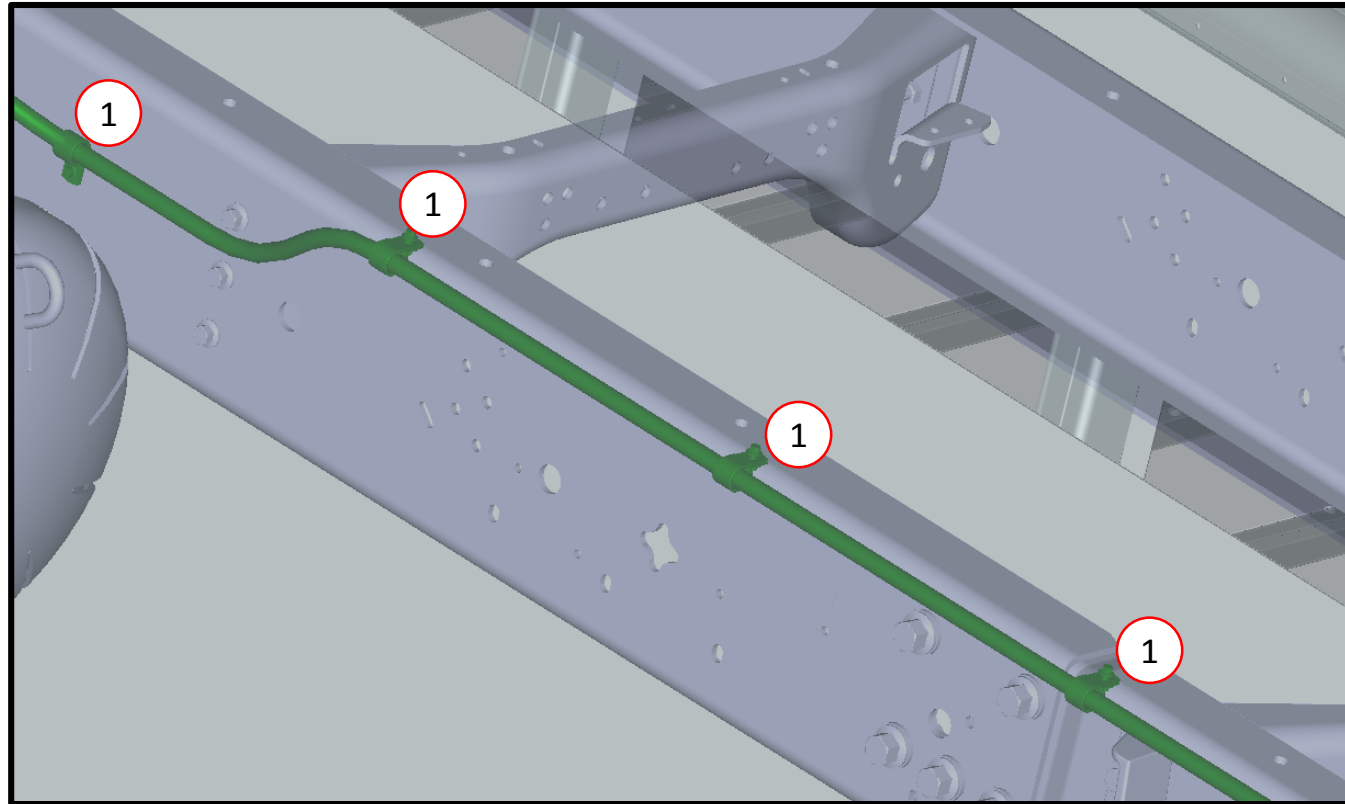

INSTALLING THE FILL SYSTEM CONT.

6. The fuel fill hose retains to the cargo floor where it passes over the tank in the two locations shown below using qty. 2 zip-tie with edge clips 20-403-0011.

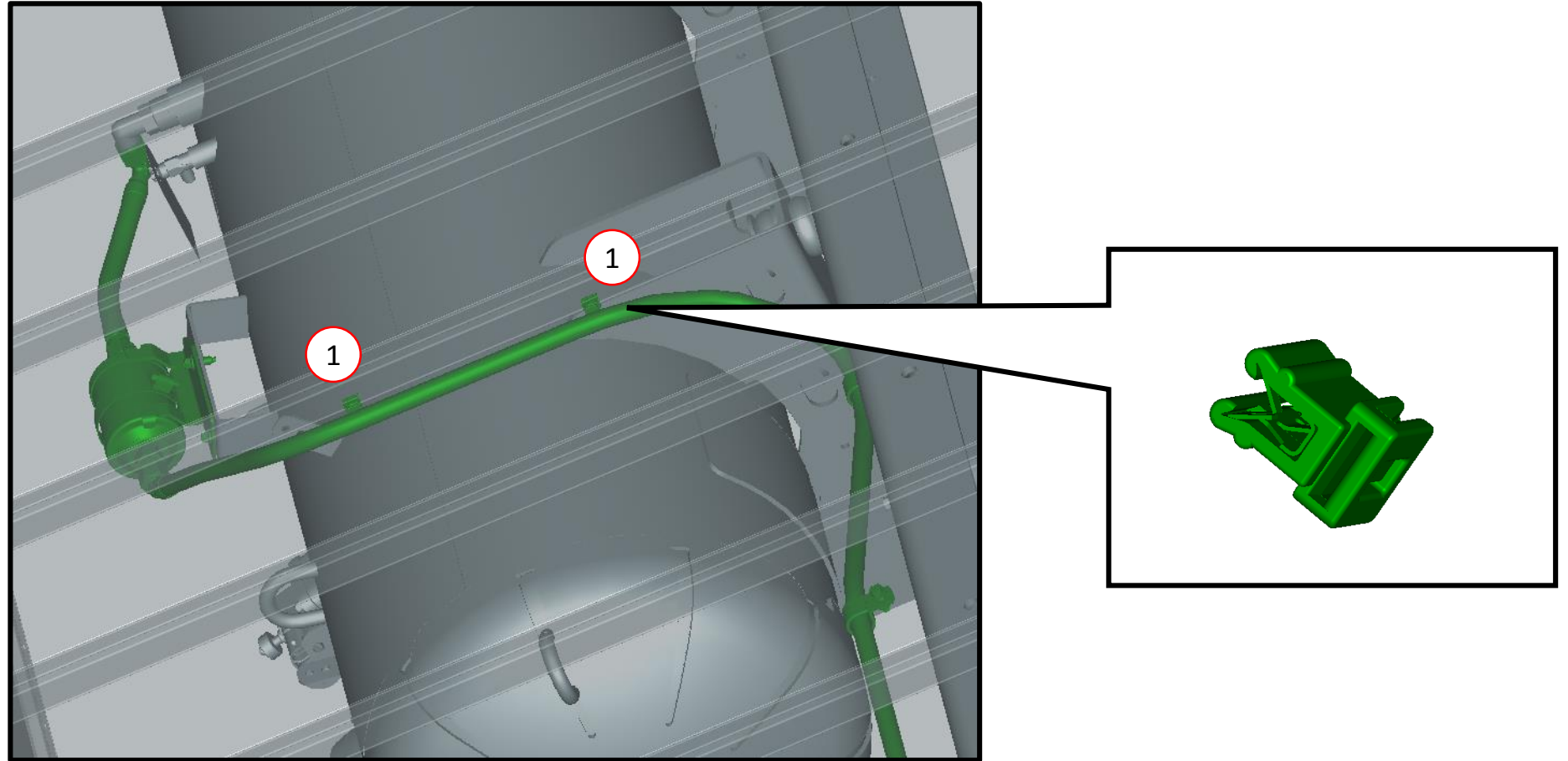

INSTALLING THE FILL SYSTEM CONT.

7. The fill hose guard P15MB-10T002-A is installed along the axle as shown below.

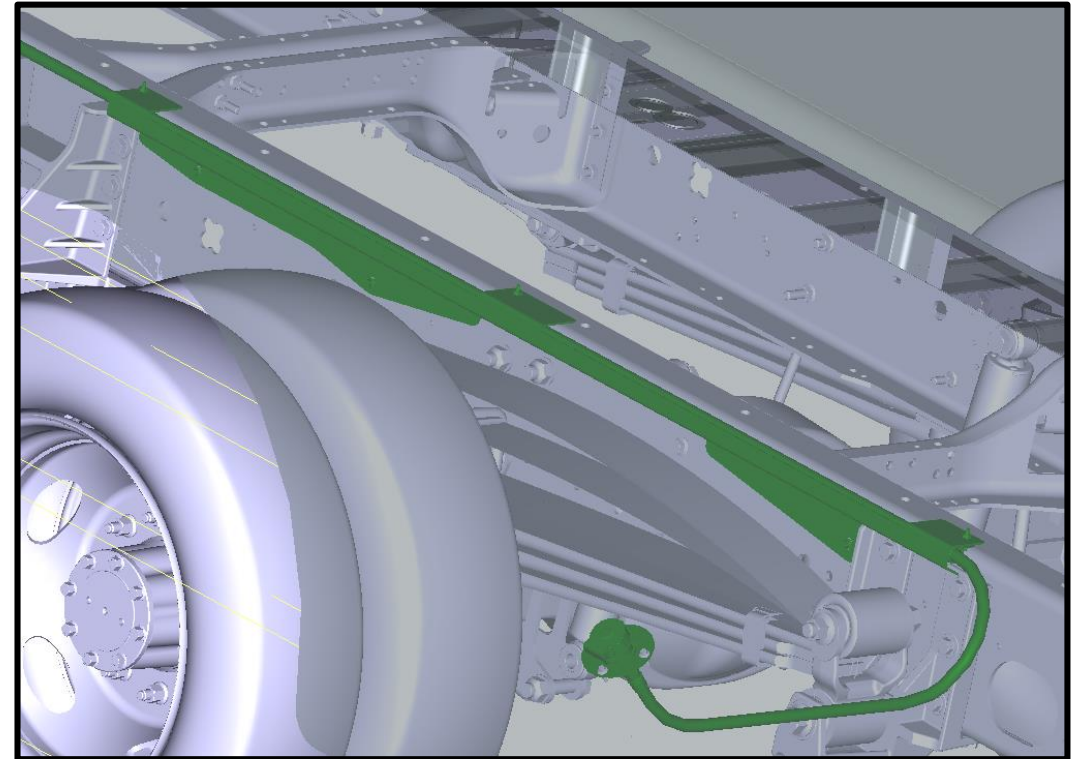
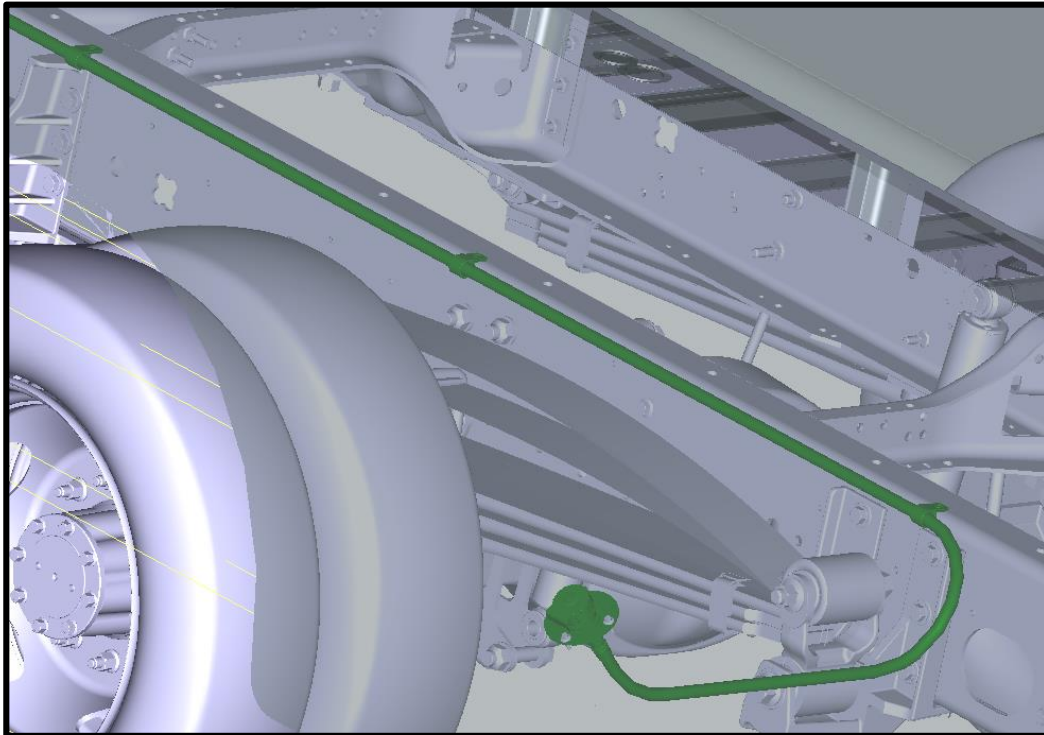

INSTALLING THE FILL SYSTEM CONT.

8. The fill hose guard P15MB-10T002-A is retained using 3 M6 bolts 98093A440 and 3 M6 nuts W702147-S438 along the frame rail. Torque to 8-12 Nm.
9. Line up the 3 P-clamps with the tabs on the top of the guard. Using 3 M6 bolts 98093A440, fasten to the M6 weld nuts on the guard. The cargo floor goes in between the guard and the P-clamp as shown below. Torque 8-12 Nm.

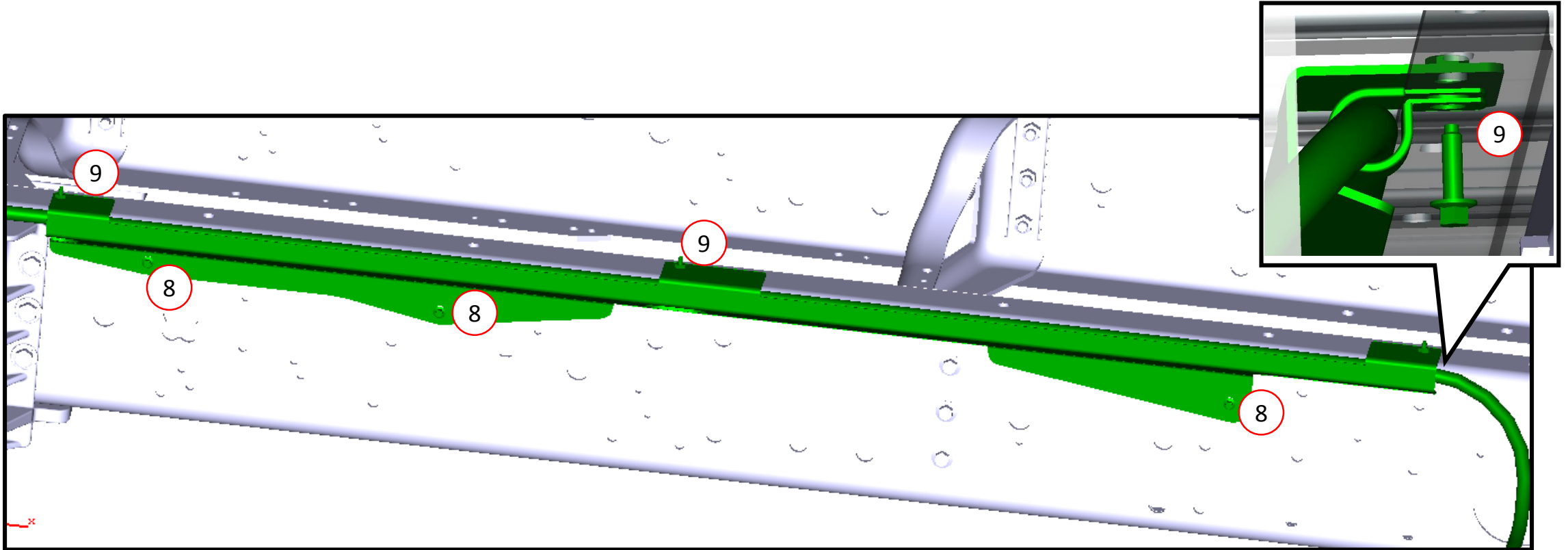

INSTALLING THE FILL SYSTEM CONT.

10. Install fuel fill valve assembly to the body mounting bracket using Qty. 3 M5x0.9x16 bolts 11-031-0583. Torque the bolts to 5–7 Nm.
11. Thread on the valve dust cover 14-6053-900 to the fill valve and retain the tether to the bracket using a nylon rivet 11-341-0561.

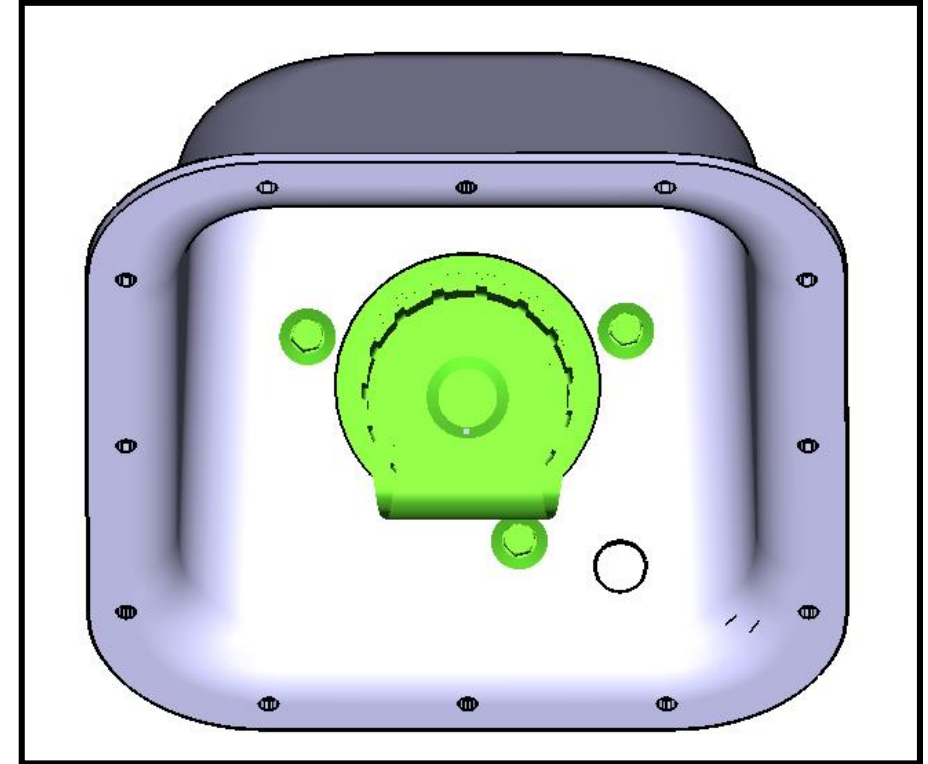
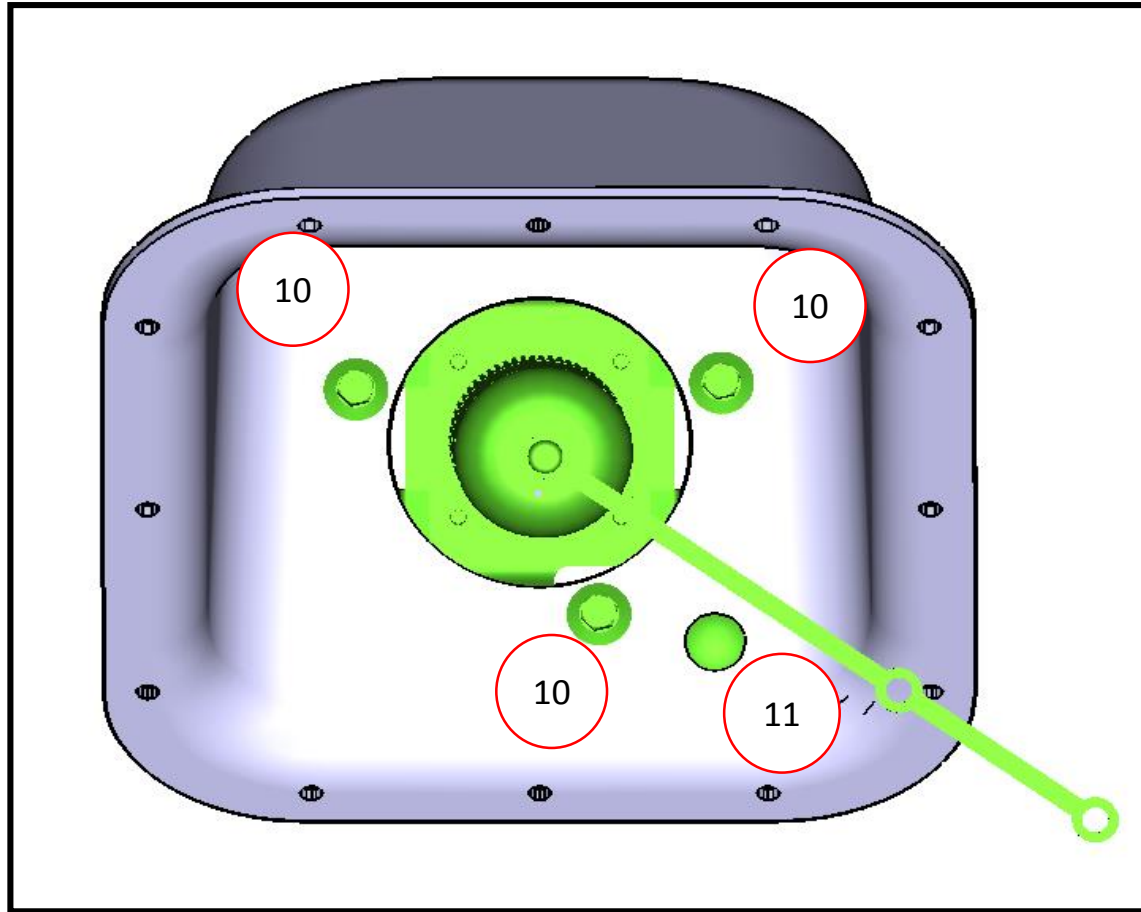

INSTALLING THE NEW ELECTRONIC FUEL PUMP RELAY (EFPR)

1. Install just rearward of the OEM EFPR. Locate reference hole on passenger side frame rail near the rear axle shown below.
2. Drill a 5/16" or 8 mm. hole in the center of the reference hole to allow an M8 bolt to go through.
3. Position new EFPR with the electrical connector orientated forward. Align the upper hole of the relay with frame rail reference hole, mark lower relay hole on frame rail and drill a 5/16" or 8 mm hole in the frame rail.
4. Use two spacers AS75-18-32 between EFPR and frame rail, position relay and install two M8 bolts 98093A558 and M8 locknuts 92461A400. Tighten to 7.6-10.4 Nm. These parts are located in hardware kit P15MB-ELECKIT-A.

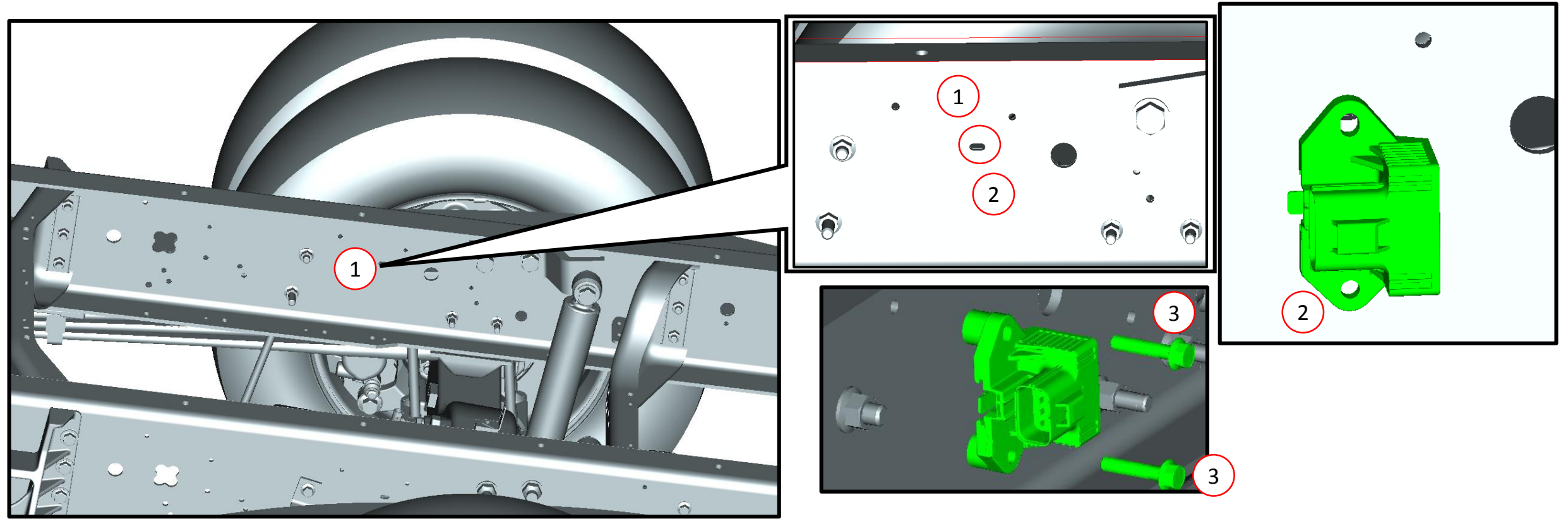

INSTALLING THE TANK VALVE GUARD.

1. Install qty. 4 M6 J-Clips W520822-S439 onto the tank valve guard tabs. The J-Clips are located in P15MB-FUELLINES-AA.

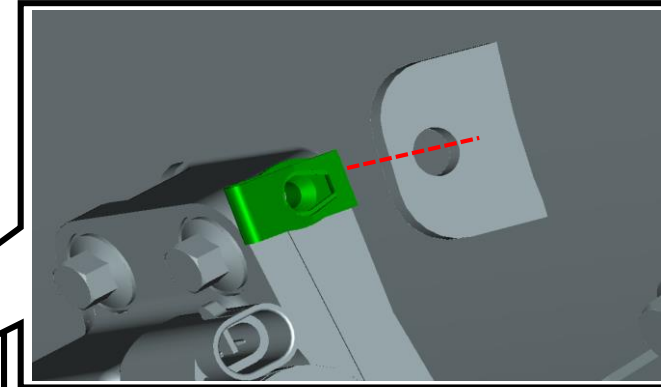
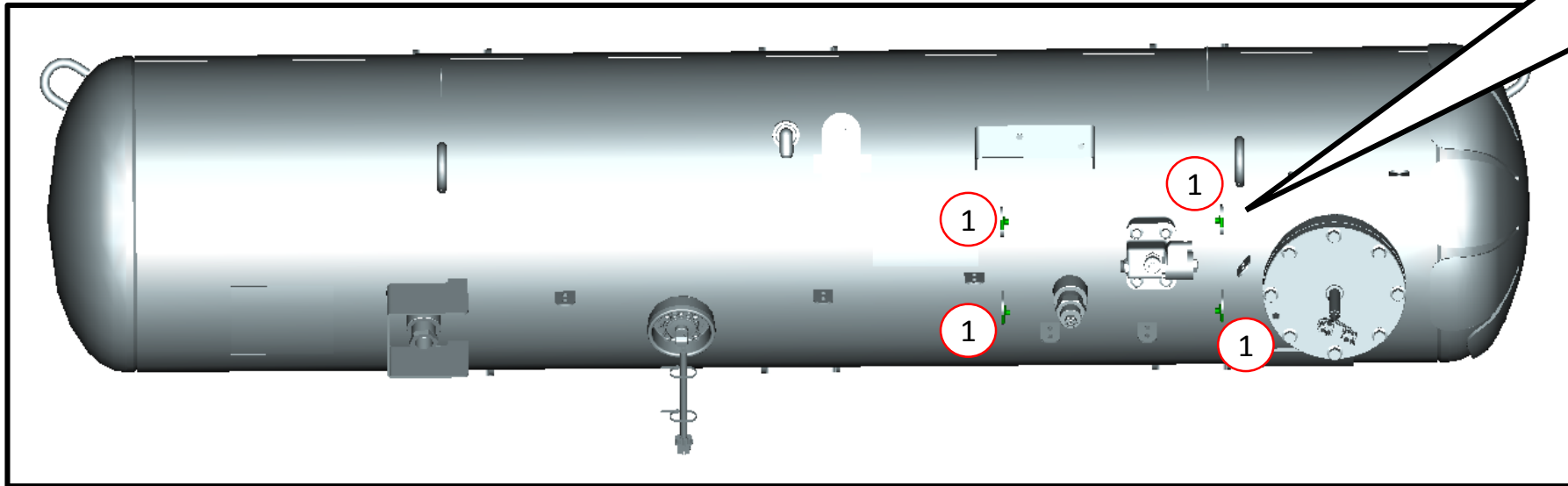

INSTALLING THE TANK VALVE GUARD CONT.

2. Locate the valve guard and install using qty. 4 M6 x 20 bolts W520214-S437 onto the tank valve guard tabs. Torque 8-12 Nm. The bolts are located in P15MB-FUELLINES-AA.

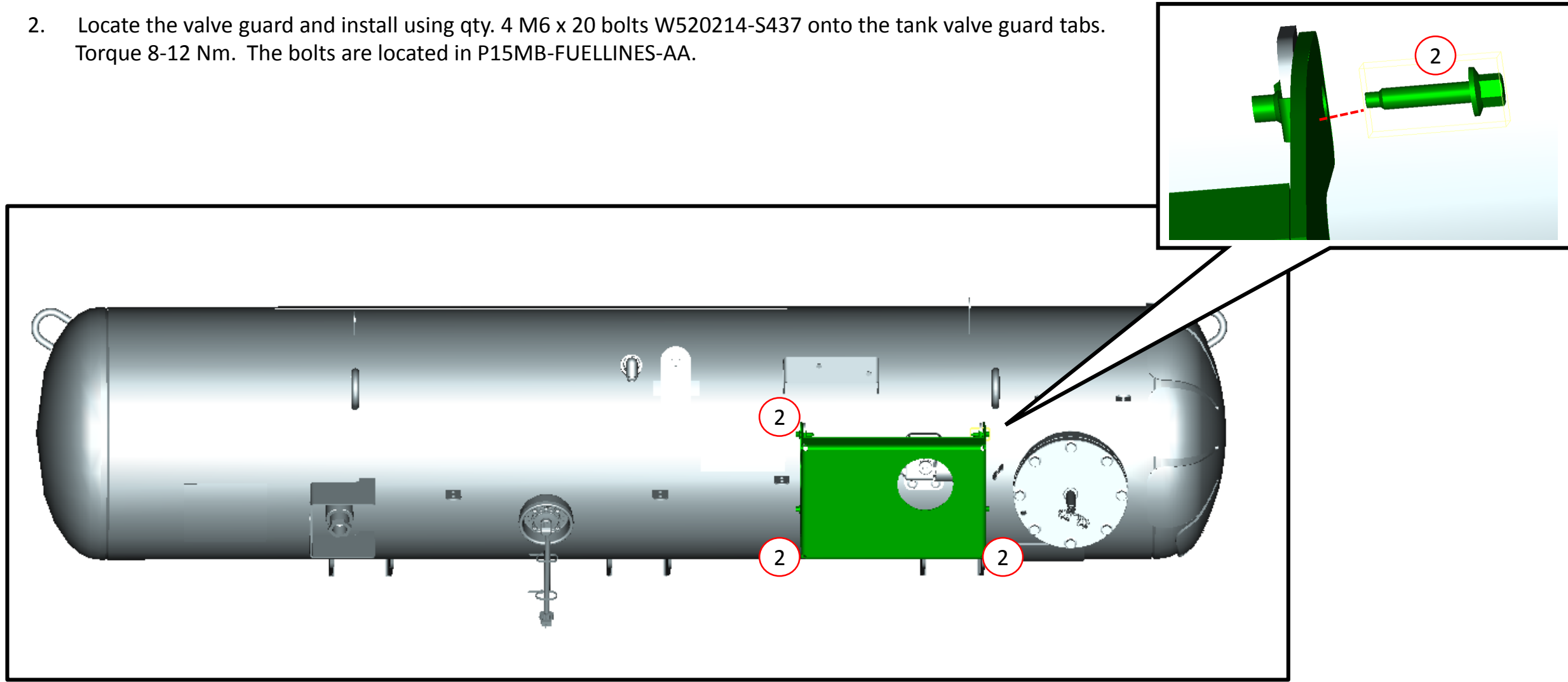

INSTALLING THE SRM/FUSE BLOCK WATER DRIP SHIELD

1. The drip shield installs above the SRM and fuse block onto the hood seal channel.
2. Remove the wiring harness retention tab from the hole shown below.
3. Center the cutout of the drip shield mounting flange with the harness retention tab hole with the orientation shown below.
4. Install the shield using two #12-14 x 0.75" self-tapping screws 91324A580.
5. Reinstall the wiring harness retention tab.

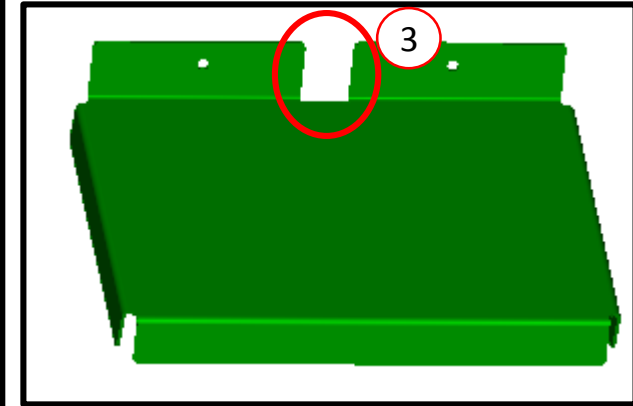
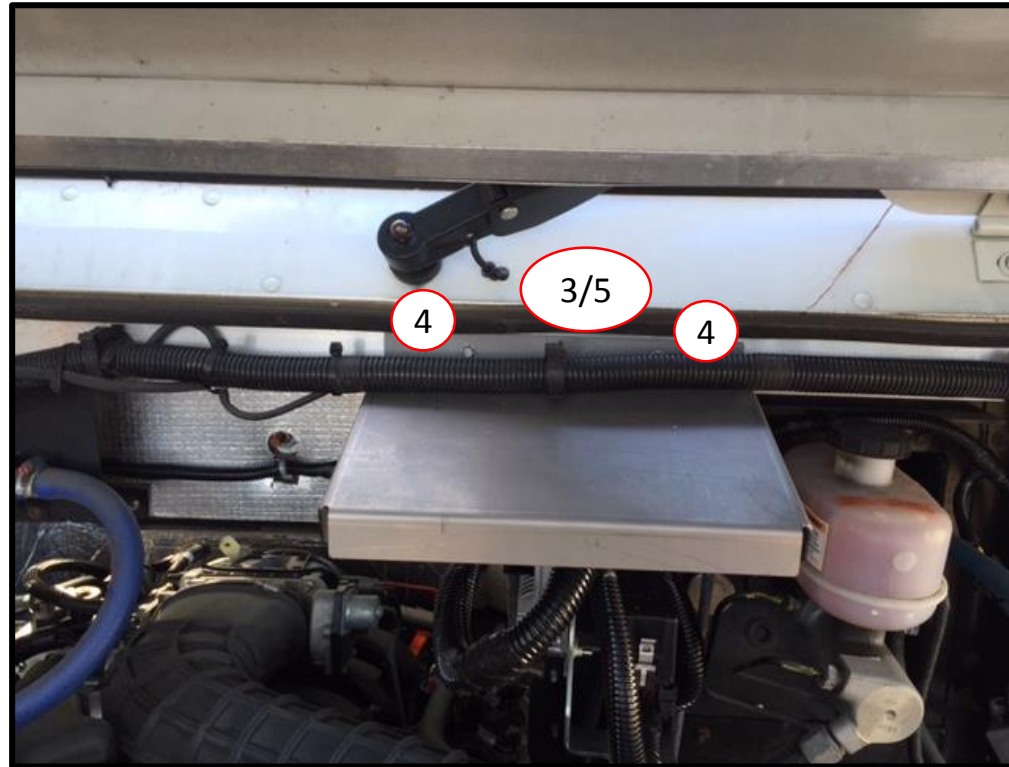

HARNESS RETENTION IDENTIFICATION

The following instructions are for installing propane kit harnesses:

1. P15MB-18A100-A Underhood harness
2. P15MB-18B100-A CAN harness
3. P15MB-18C200-A Rear Frame harness
4. P15MB-18K377-A Tank harness

***** READ BEFORE STARTING THE INSTALLATION *****

There are 4 types of retainers in the Electrical Kit to retain harnesses.

1. Tie Straps (20-403-0003) are typically used to retain to the OEM harness. These tie straps are also used to retain the Tank harness to the propane fuel tank.



2. Use 2 Offset Fir Tree Clip (157-403-0013) to retain Underhood harness to engine compartment dash panel.



3. Plastic Edge Clips (20-403-0011) retain a portion of the Underhood harness in engine compartment.

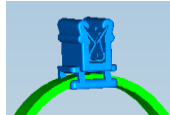

4. Retain Rear Frame Harness below frame using P-Clamp P/N 11-056-0042 as outlined later in this guide.



HARNES ROUTE OVERVIEW

WIRING OVERVIEW FOR FRONT HALF OF TRUCK

FRONT OF VEHICLE ←

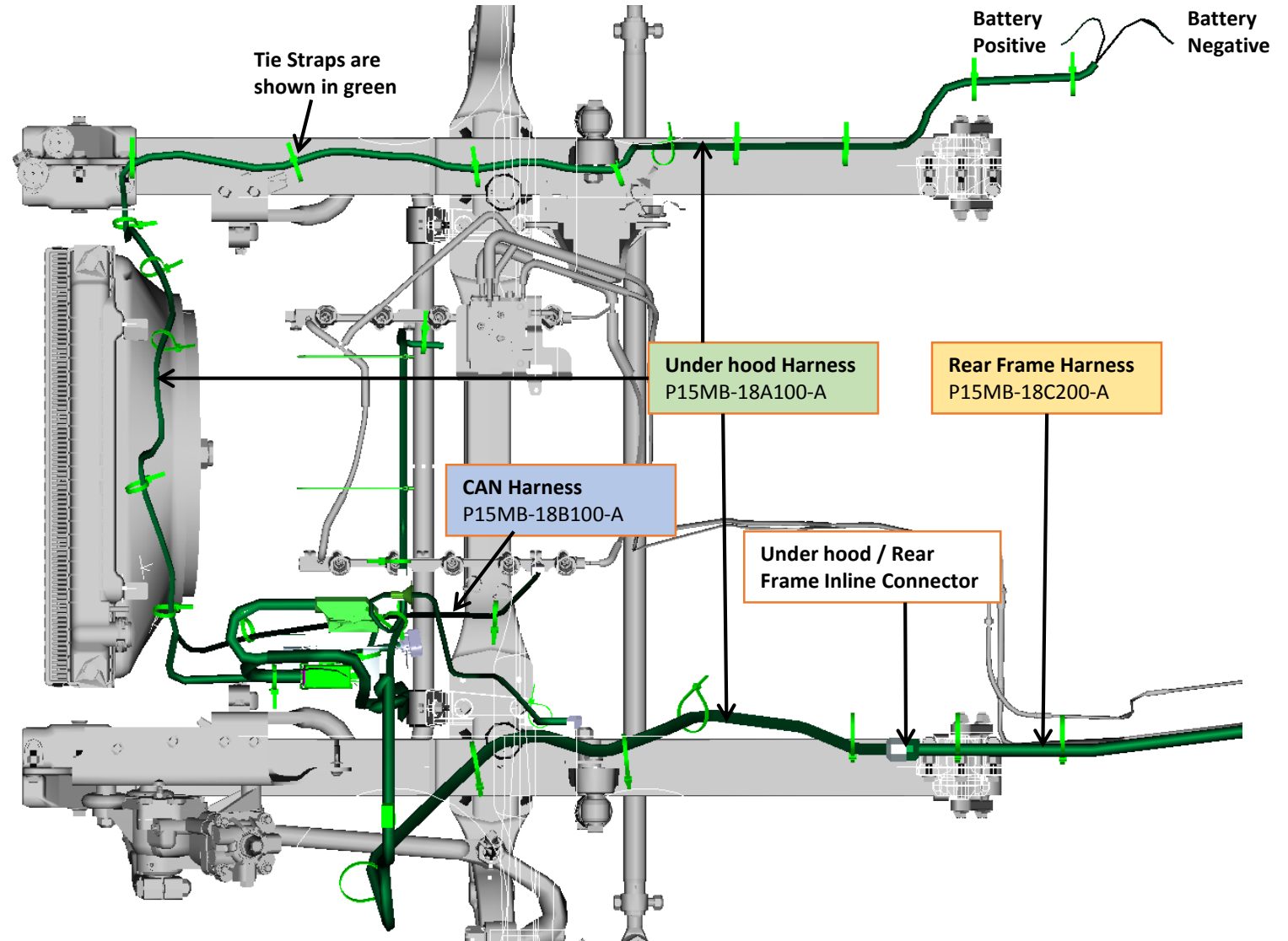

CAN HARNESS GROMMET HOLE LOCATION

Use hole saw to drill 29mm (1 1/8") hole in dash panel sheet metal for CAN Harness pass thru. Make sure there is clearance on other side of sheet metal before drilling.

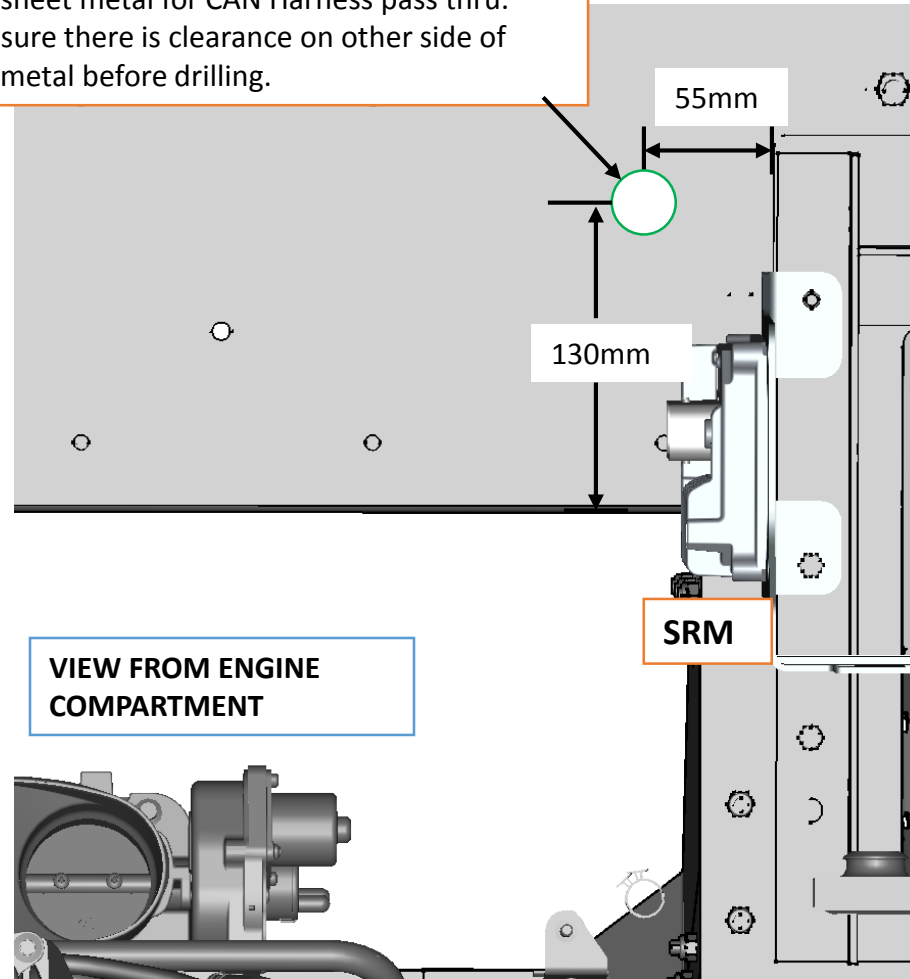

CAN HARNESS GROMMET INSTALLED

VIEW FROM ENGINE
COMPARTMENT

Pull CAN Harness through 29mm (1 1/8")
hole and seat grommet to make proper
seal.

CAN Harness
P15MB-18B100-A

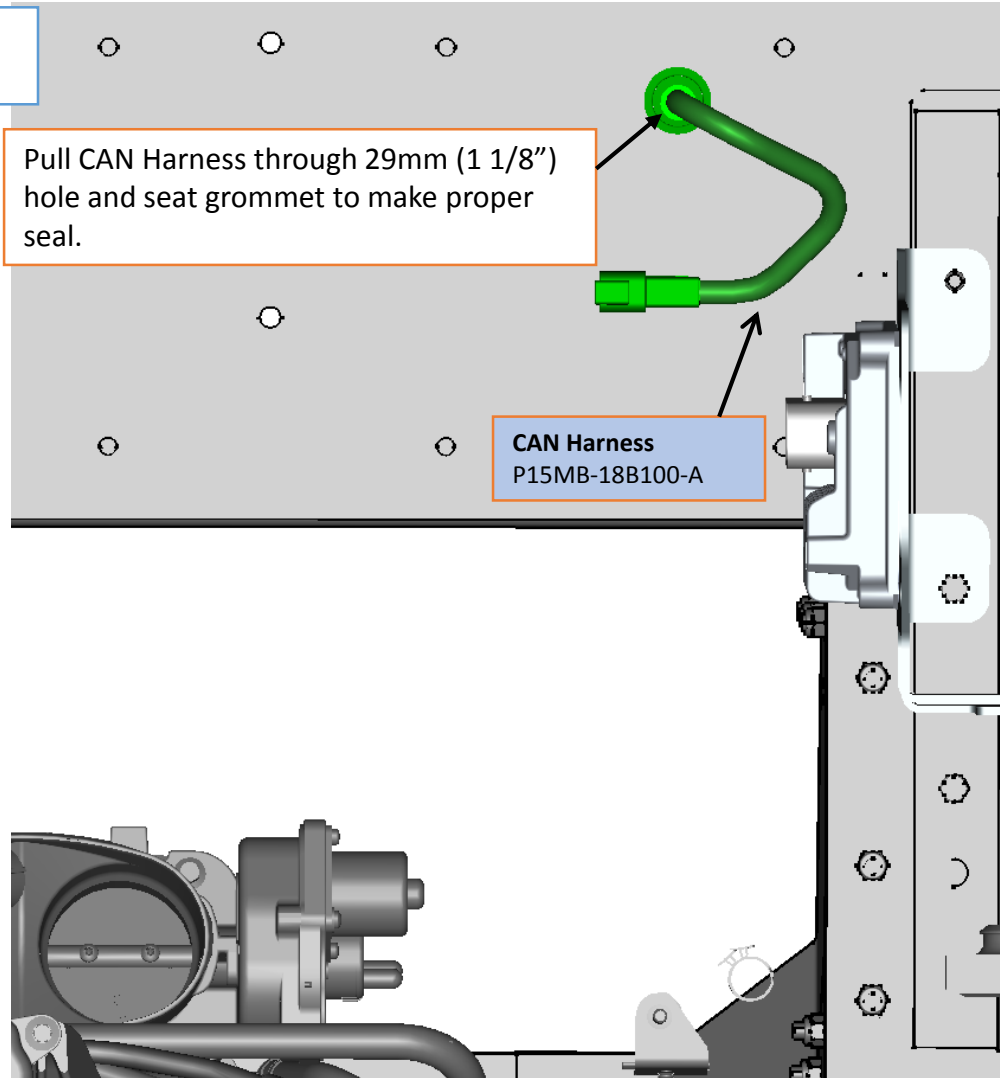

CAN HARNESS INSTALLATION CONT.

VIEW FROM VEHICLE CABIN

Remove the fasteners that are retaining the OEM OBD2 connector. Reuse hardware to attach RCT CAN harness OBD connector in position.

Next, plug OEM OBD connector into CAN harness male OBD connector.

CAN Harness
P15MB-18B100-A

Last, secure harness about 100mm on each side of mated OBD connectors using 2 tie straps.

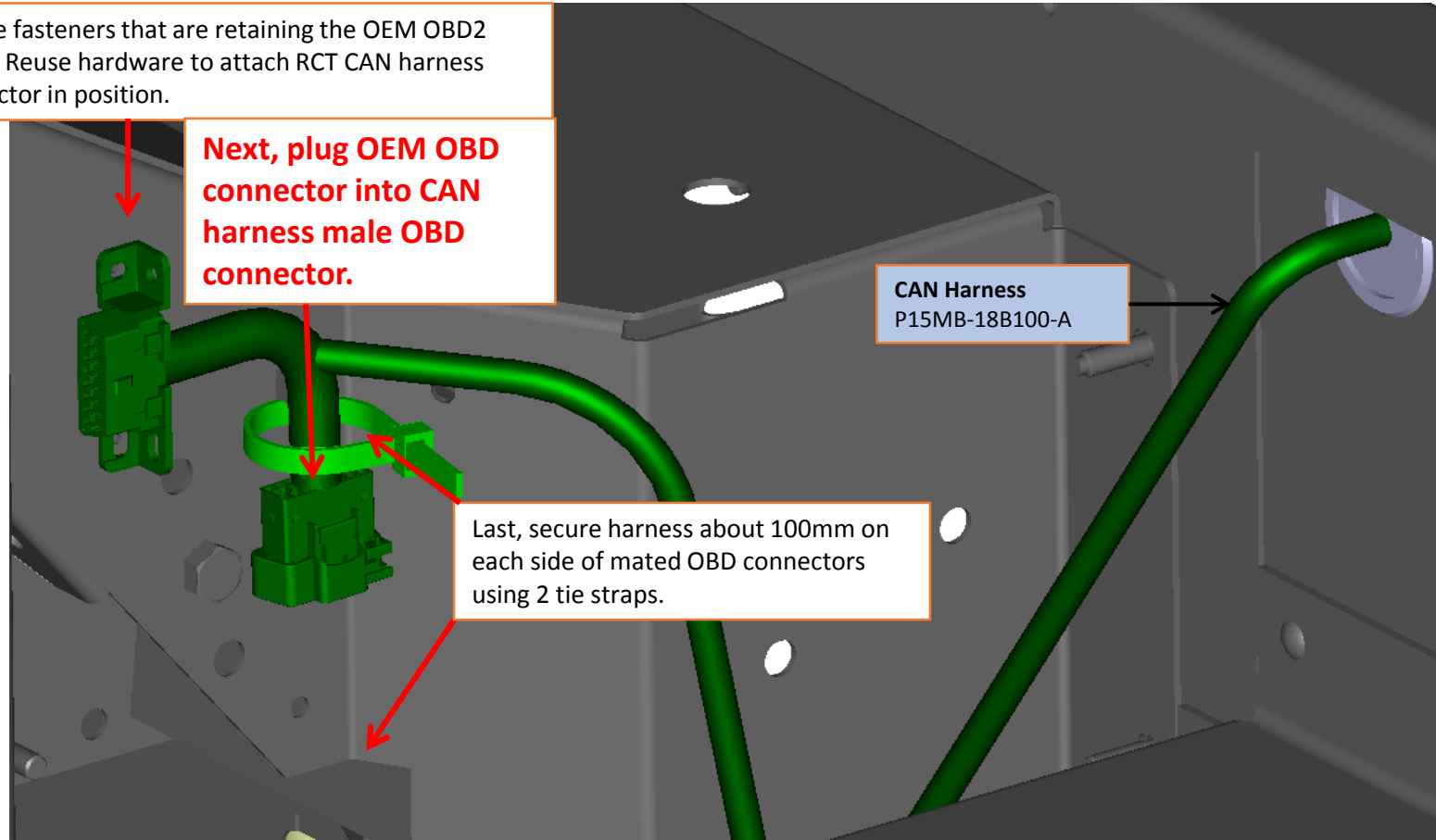

UNDER HOOD HARNESS ROUTE ALONG VEHICLE FRAME

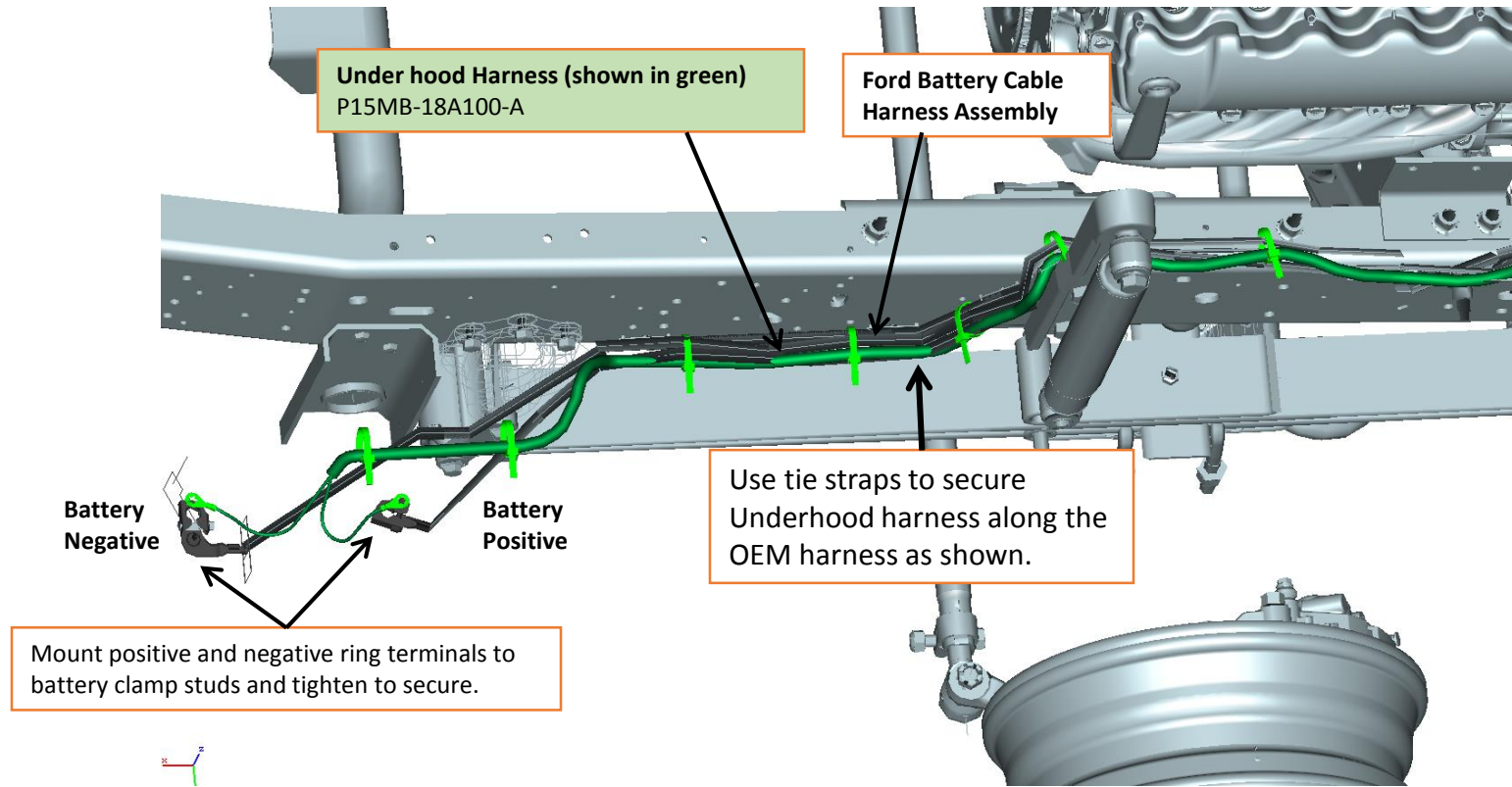

UNDER HOOD HARNESS ROUTE ALONG ENGINE COMPARTMENT

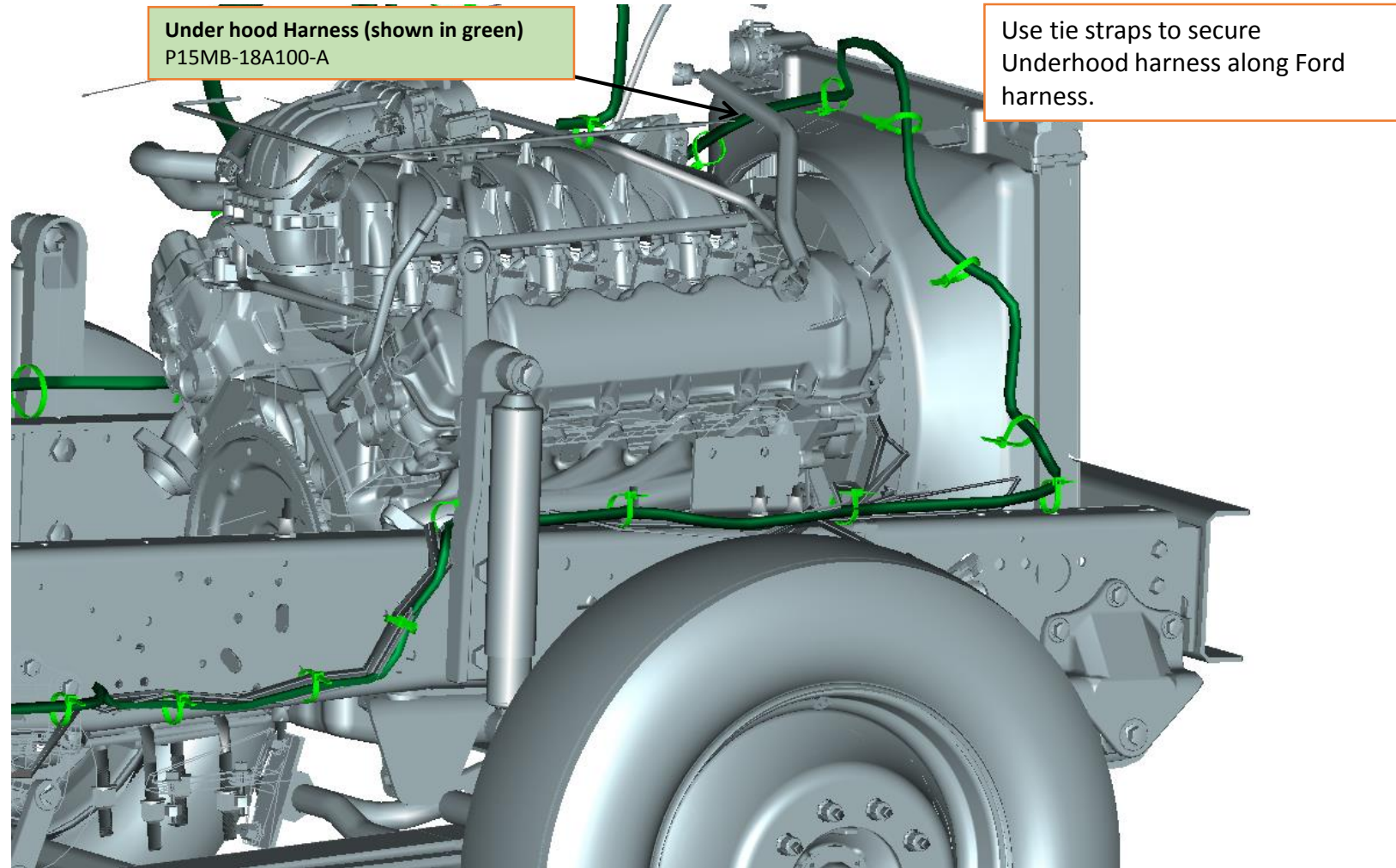

UNDER HOOD HARNESS CONNECTIONS

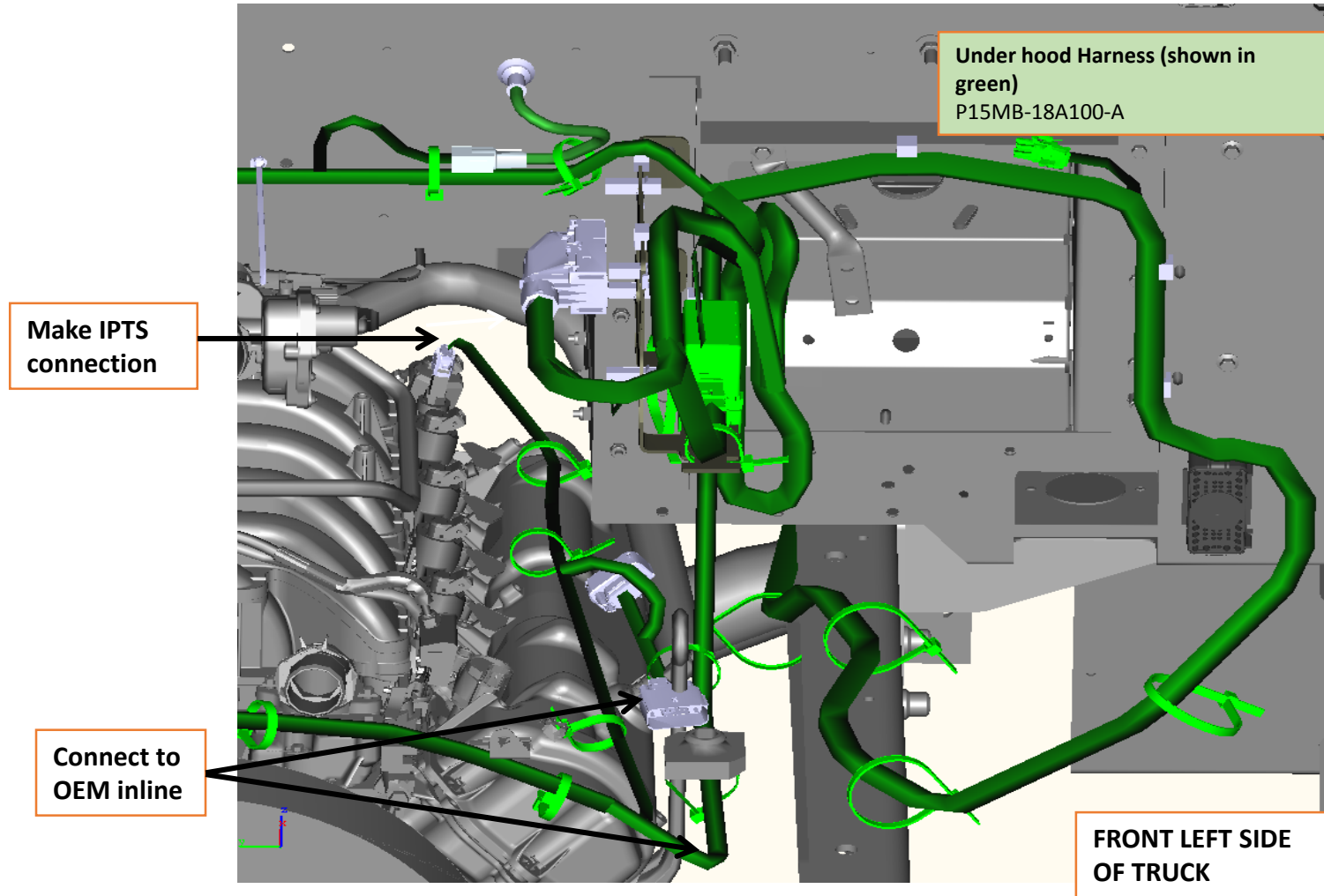

UNDER HOOD HARNESS ROUTE ALONG ENGINE COMPARTMENT CONT.

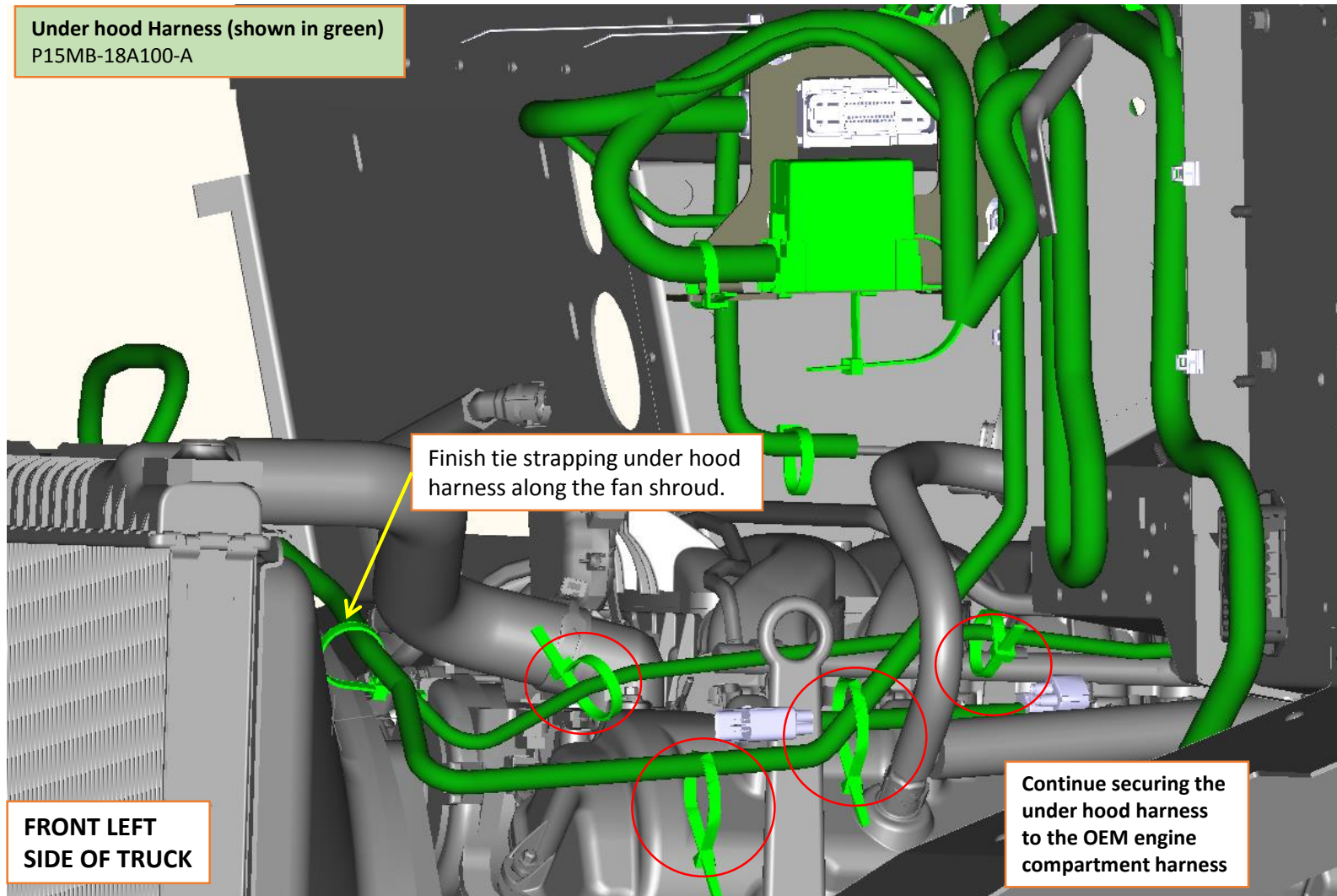

UNDER HOOD HARNESS CONNECTIONS CONT.

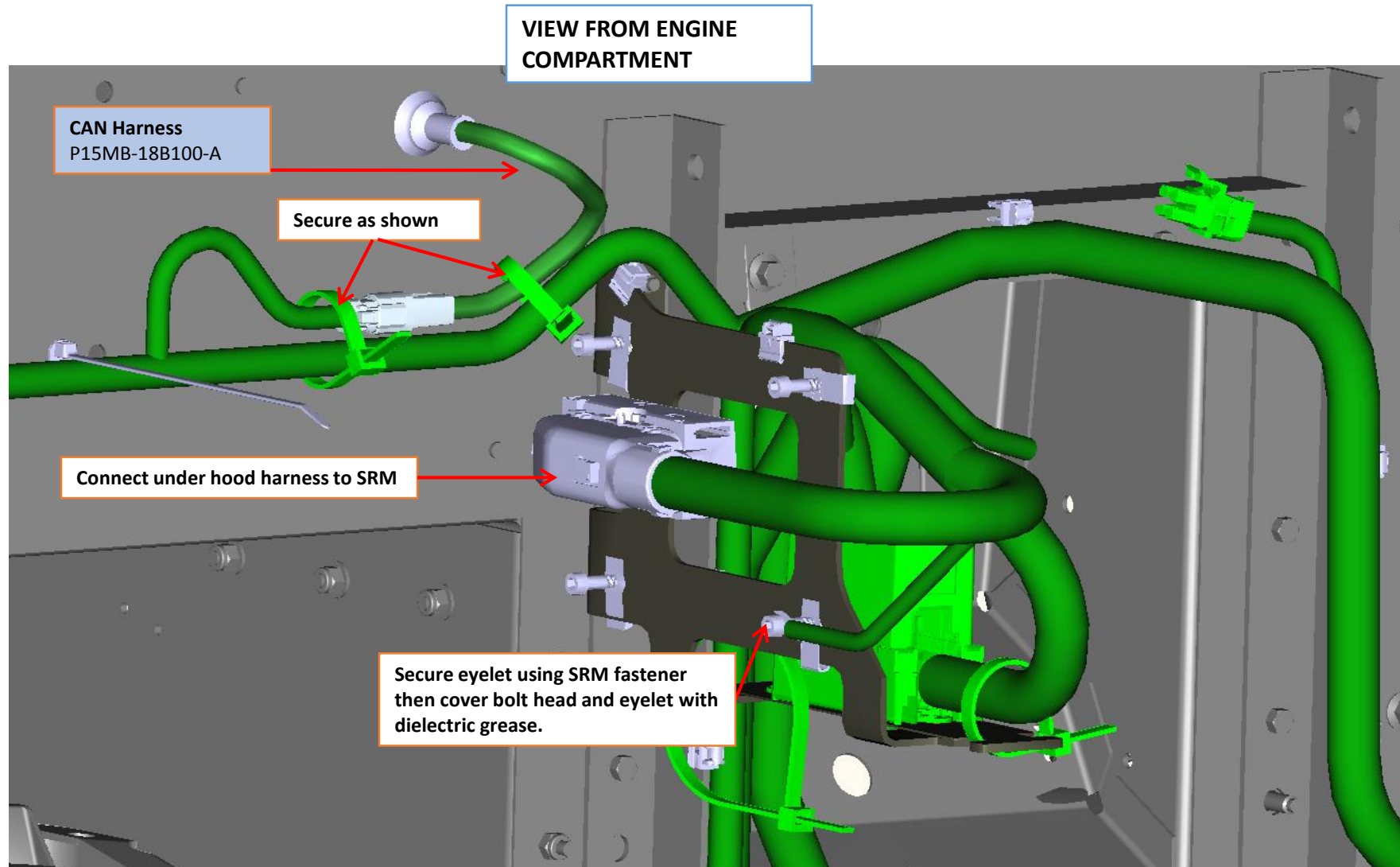

UNDER HOOD HARNESS FUSE BOX LOCATION

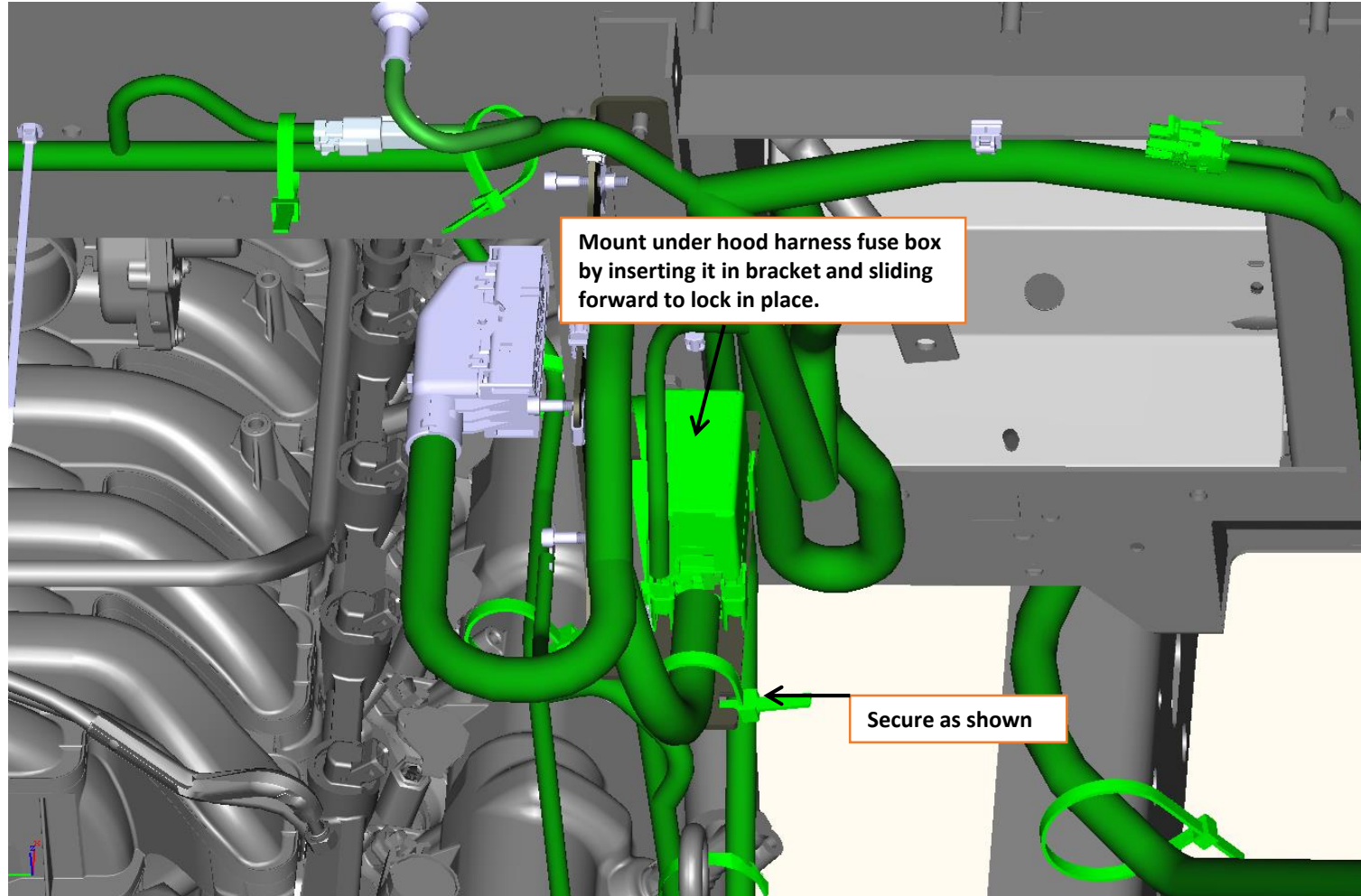

UNDER HOOD HARNESS ROUTE AND RETENTION

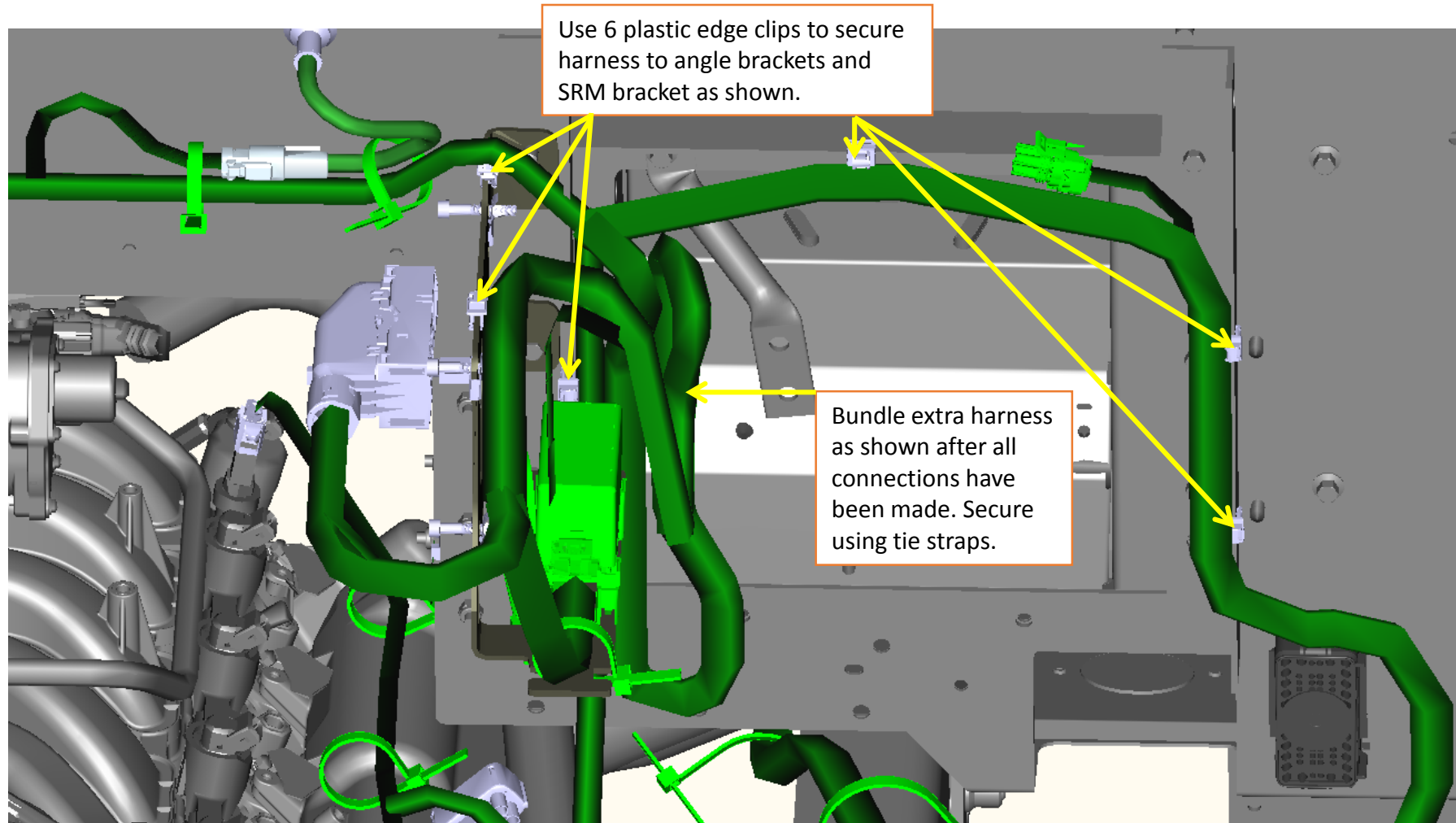

UNDER HOOD HARNESS TO FUEL LEVEL INTERFACE MODULE

Install fuel level interface module and secure to the harness as shown.

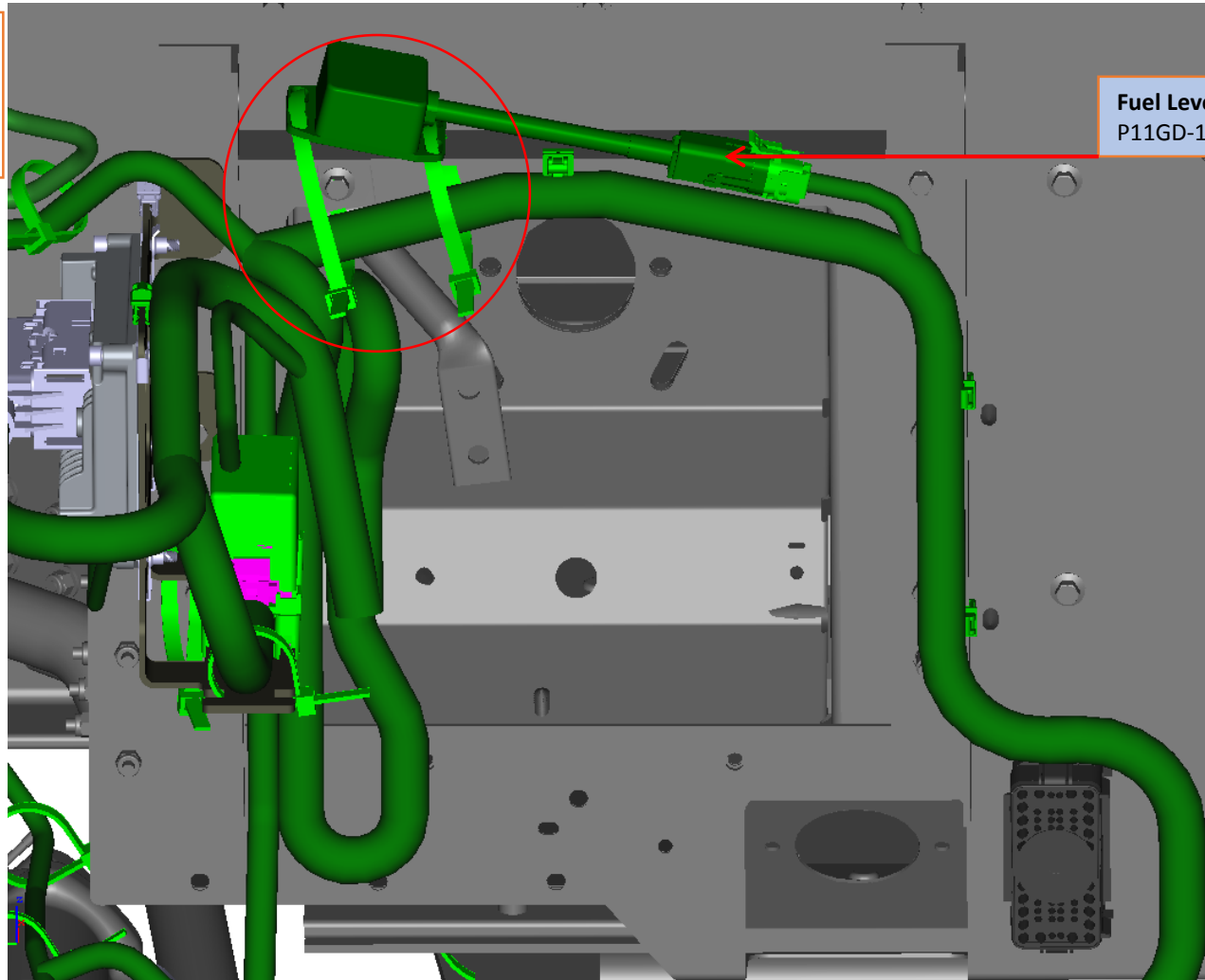

Fuel Level Interface Module
P11GD-18L100-B

UNDER HOOD HARNESS ROUTE AND RETENTION CONT.

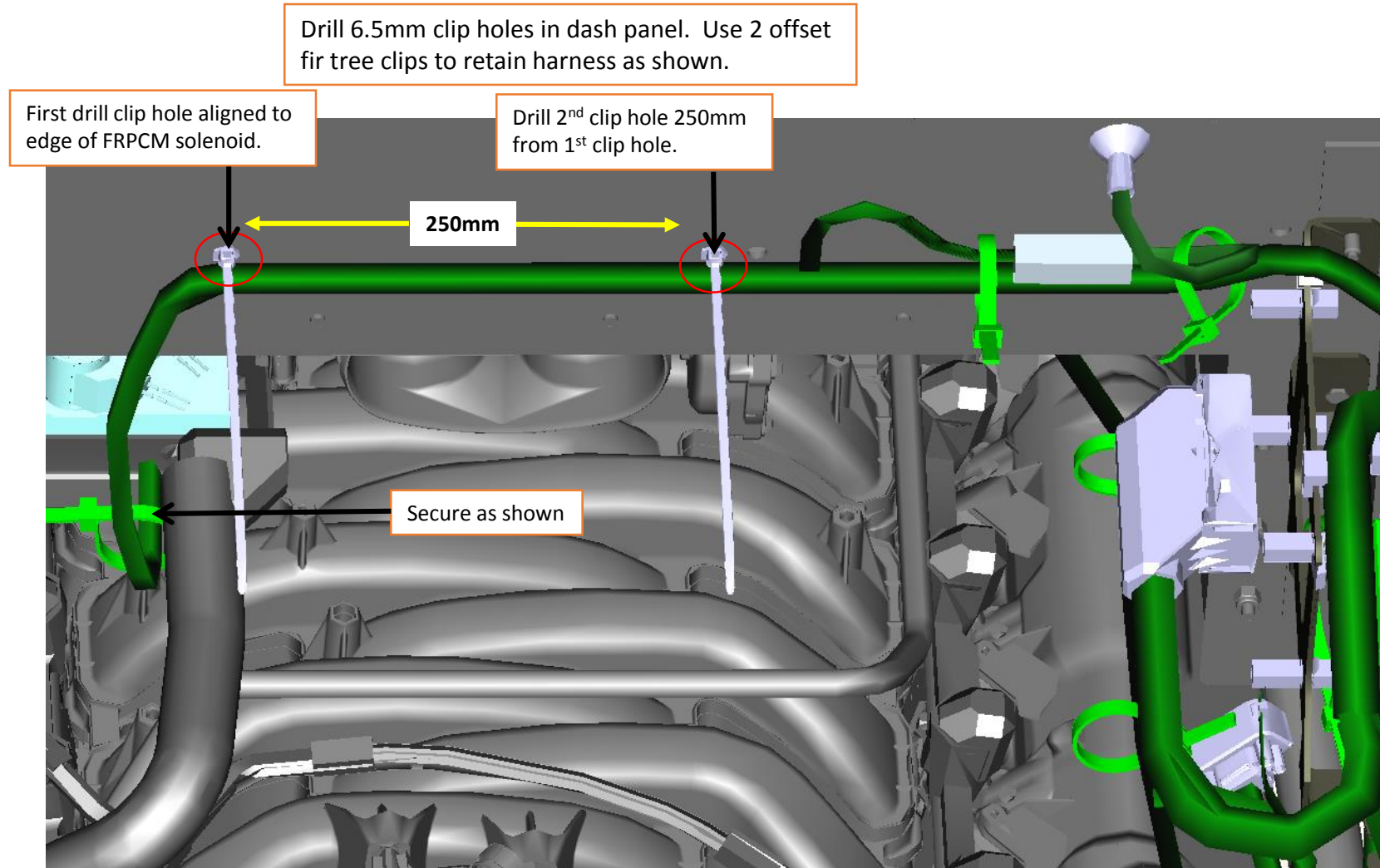

UNDER HOOD HARNESS TO FRPCM

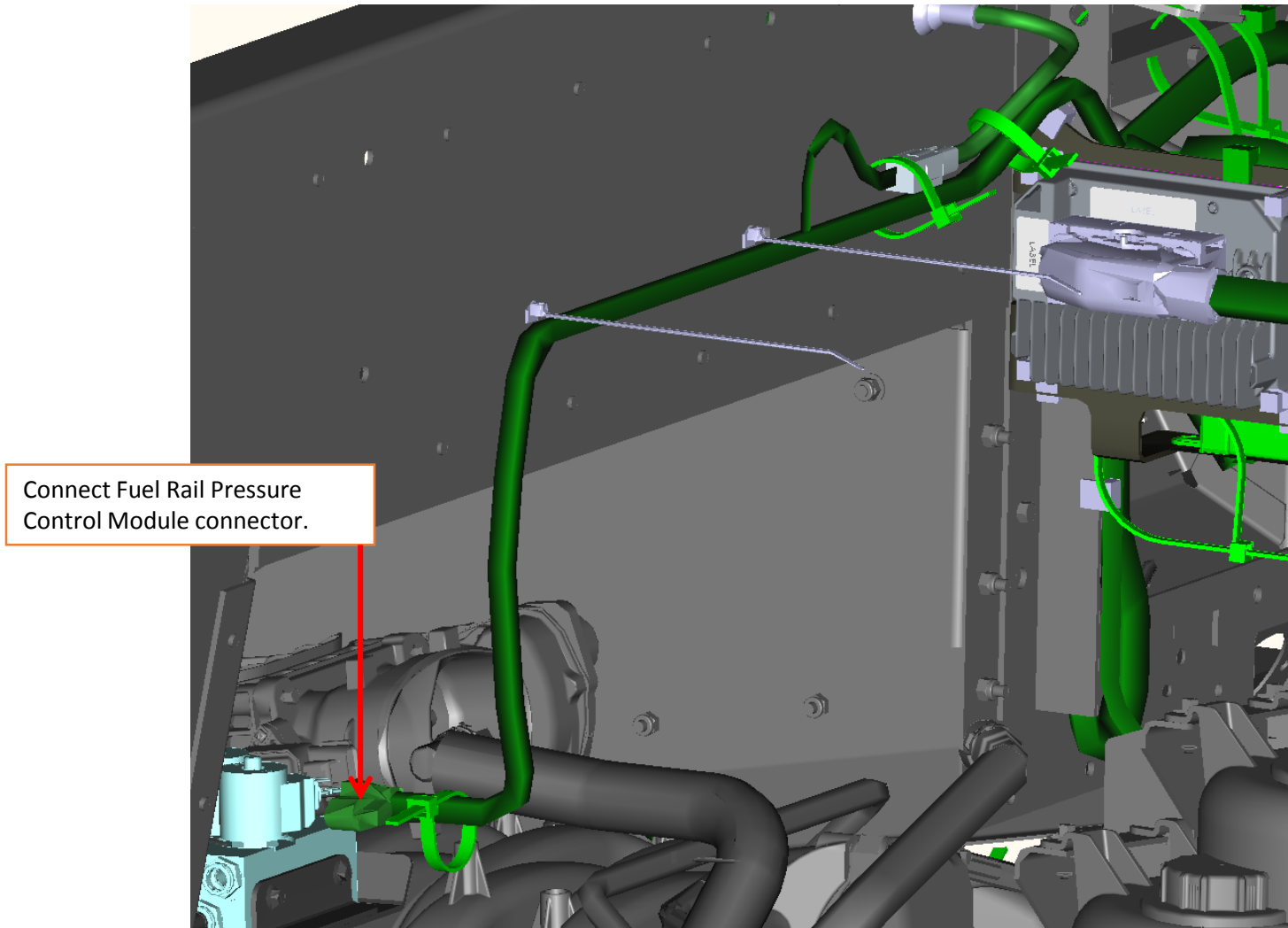

UNDER HOOD HARNESS ROUTE AND RETENTION CONT.

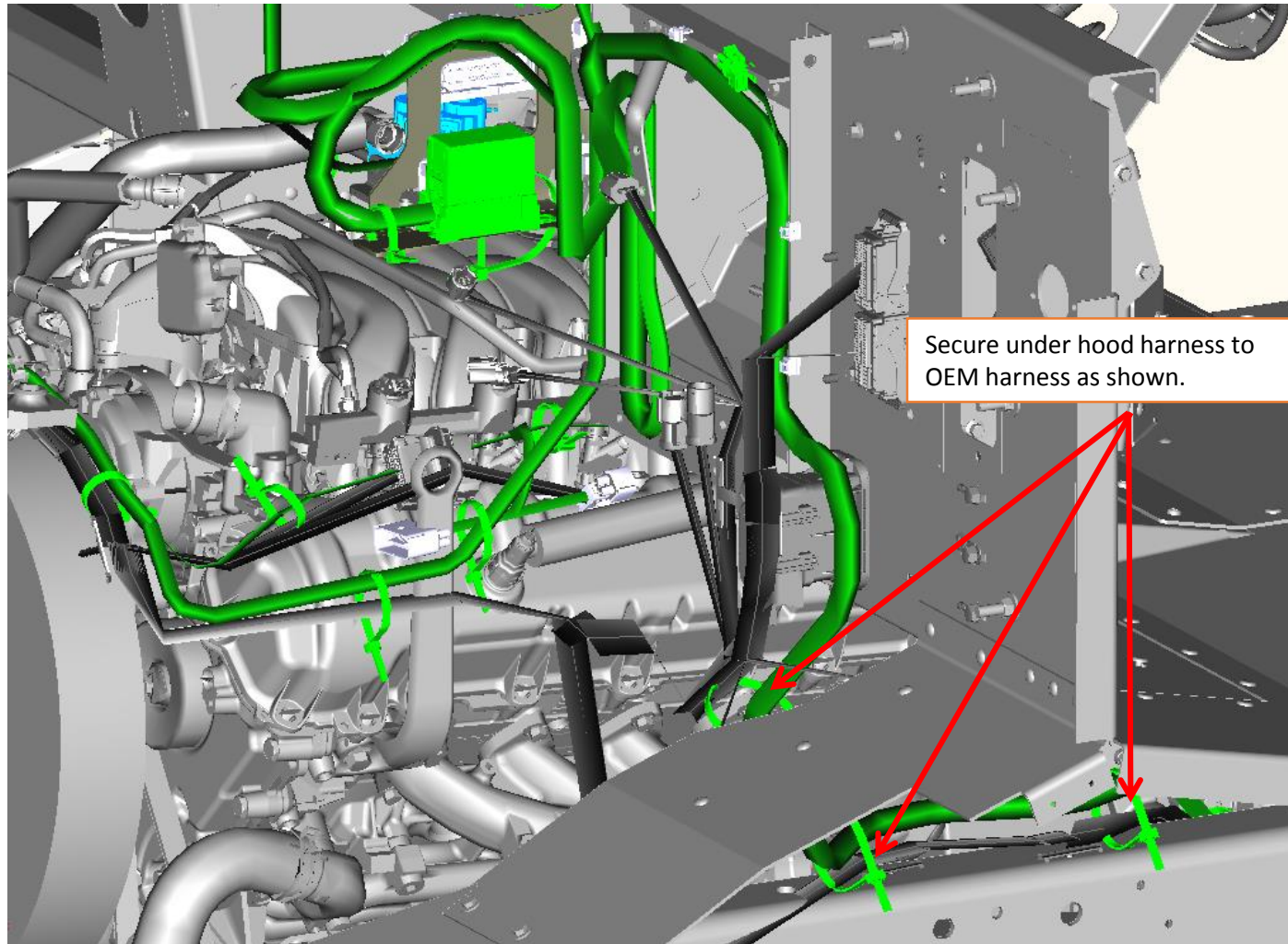

HARNESS ROUTE OVERVIEW CONT.

The harness routing in the engine compartment area should be finished.
The rest of the installation is for the rear half of vehicle as shown below.

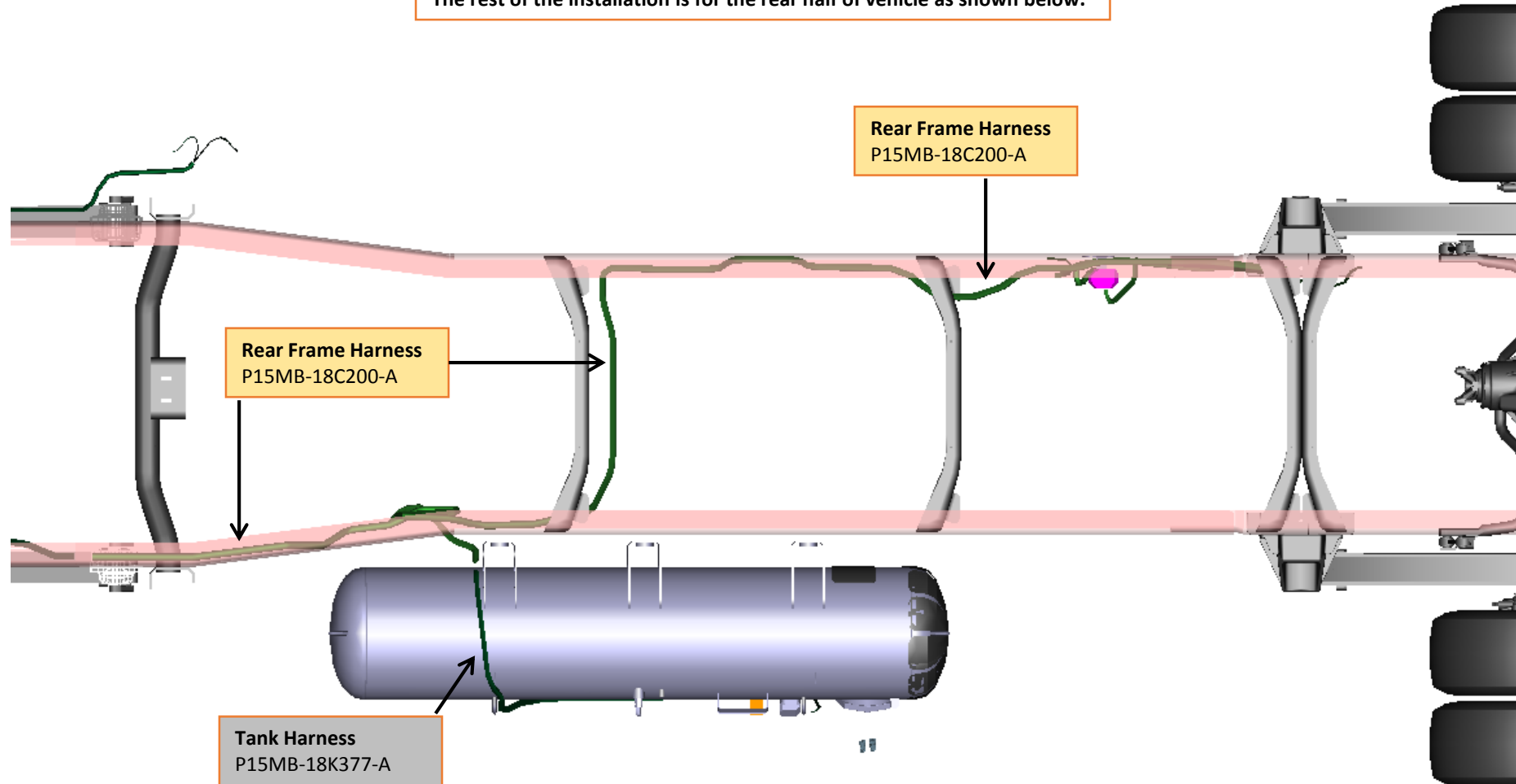

REAR FRAME HARNESS TO UNDER HOOD HARNESS

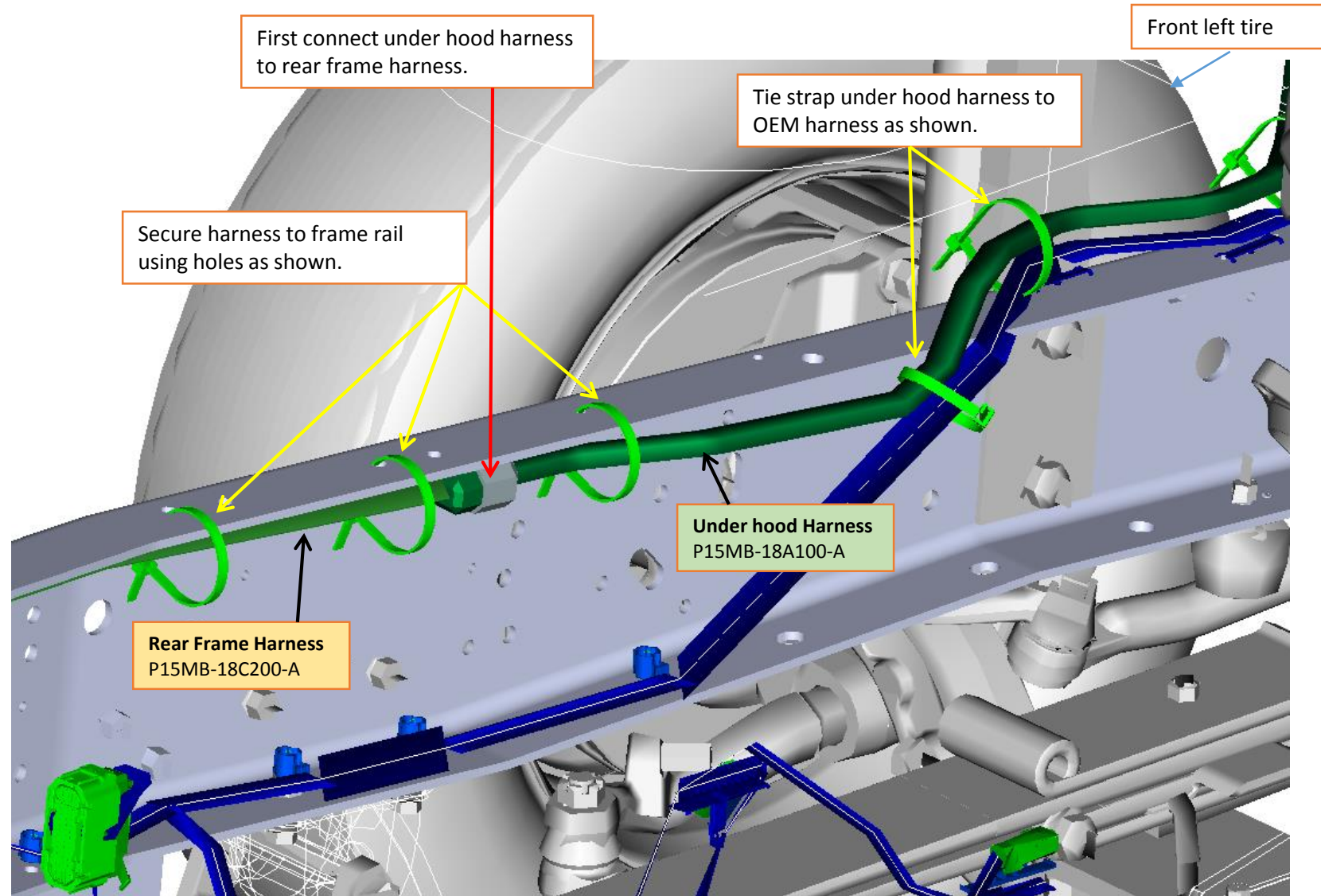

REAR FRAME HARNESS ROUTE AND RETENTION

Tie strap rear frame harness to OEM harness as shown.

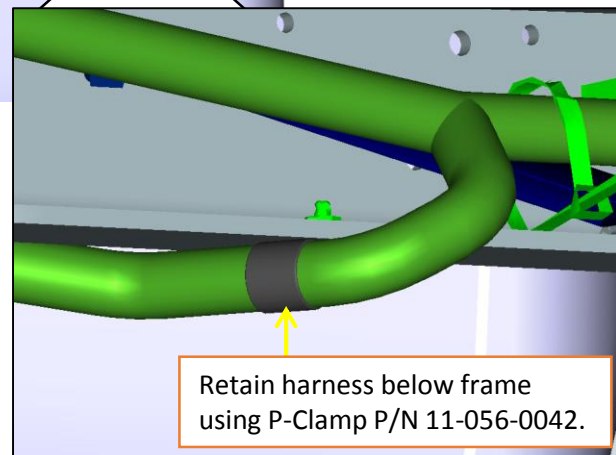
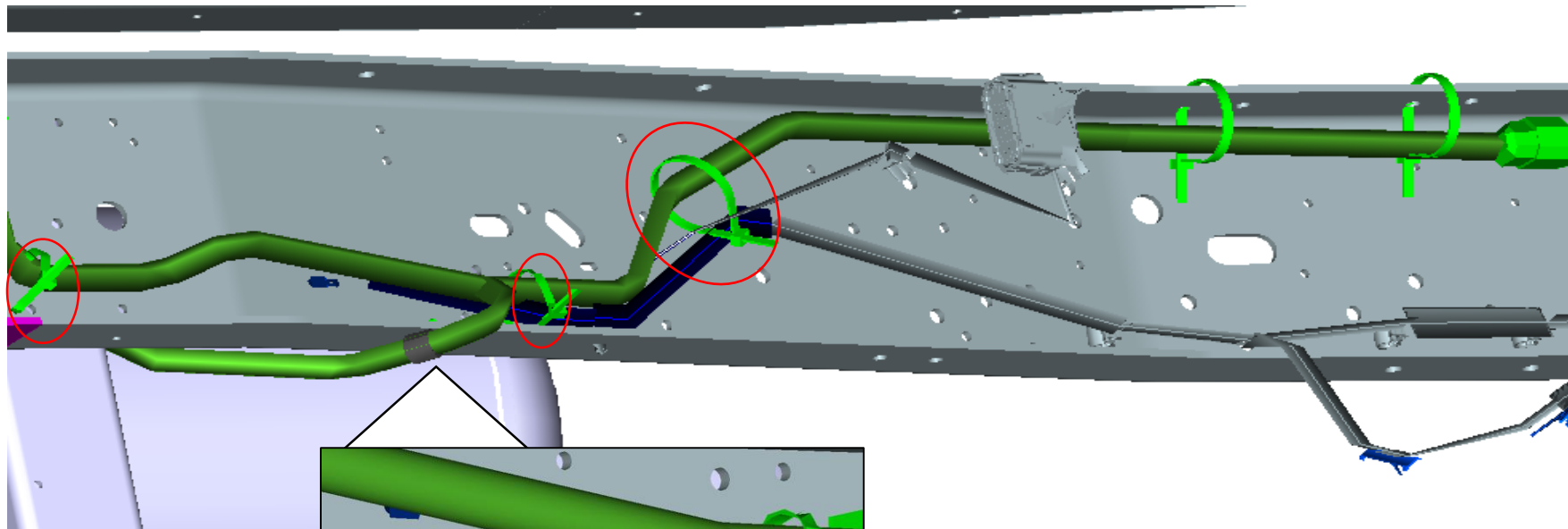

Retain harness below frame using P-Clamp P/N 11-056-0042.

REAR FRAME HARNESS ROUTE AND RETENTION CONT.

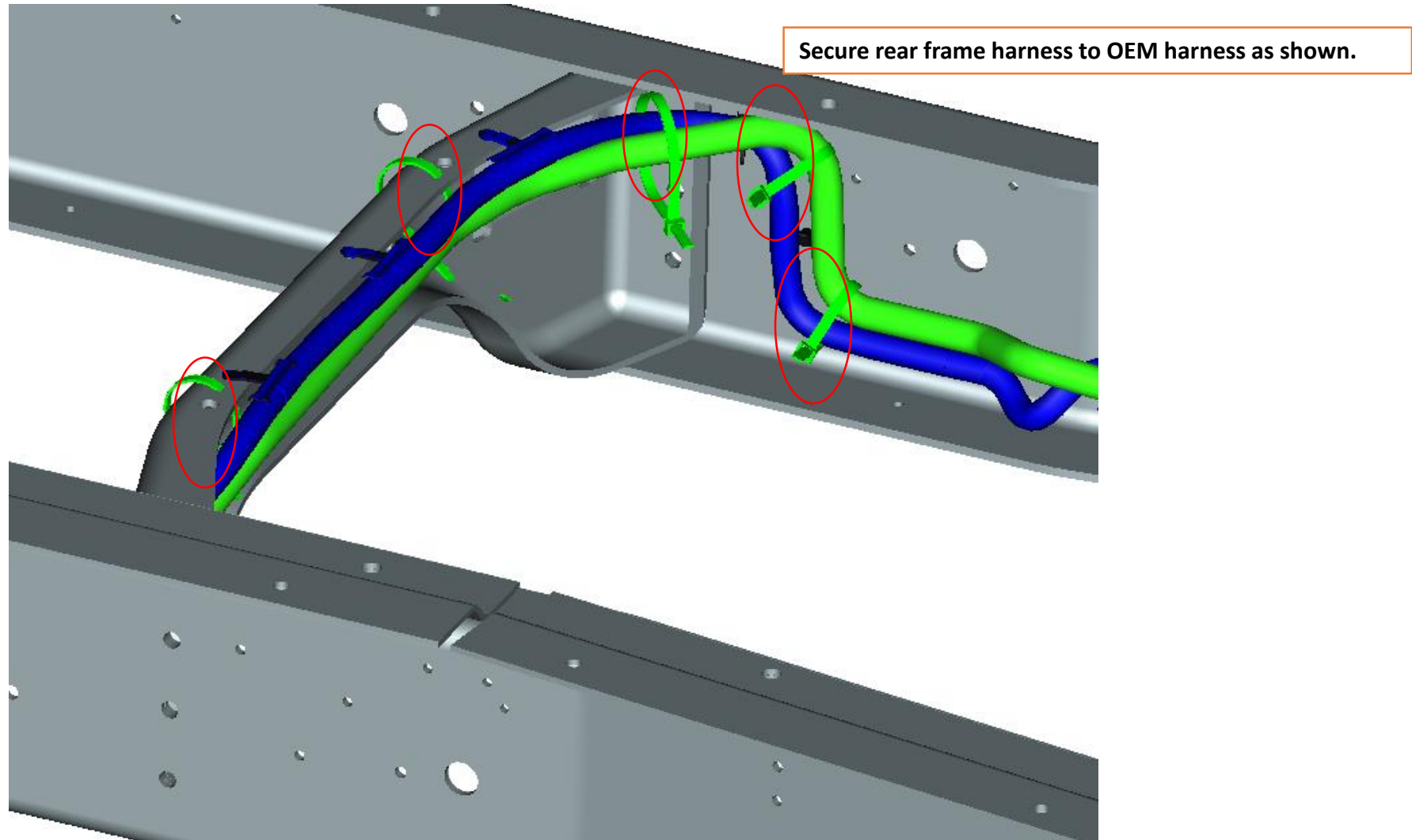

REAR FRAME HARNESS ROUTE AND RETENTION CONT.

Position rear frame harness through 2 cross members before tie strapping to OEM harness. See next slide.

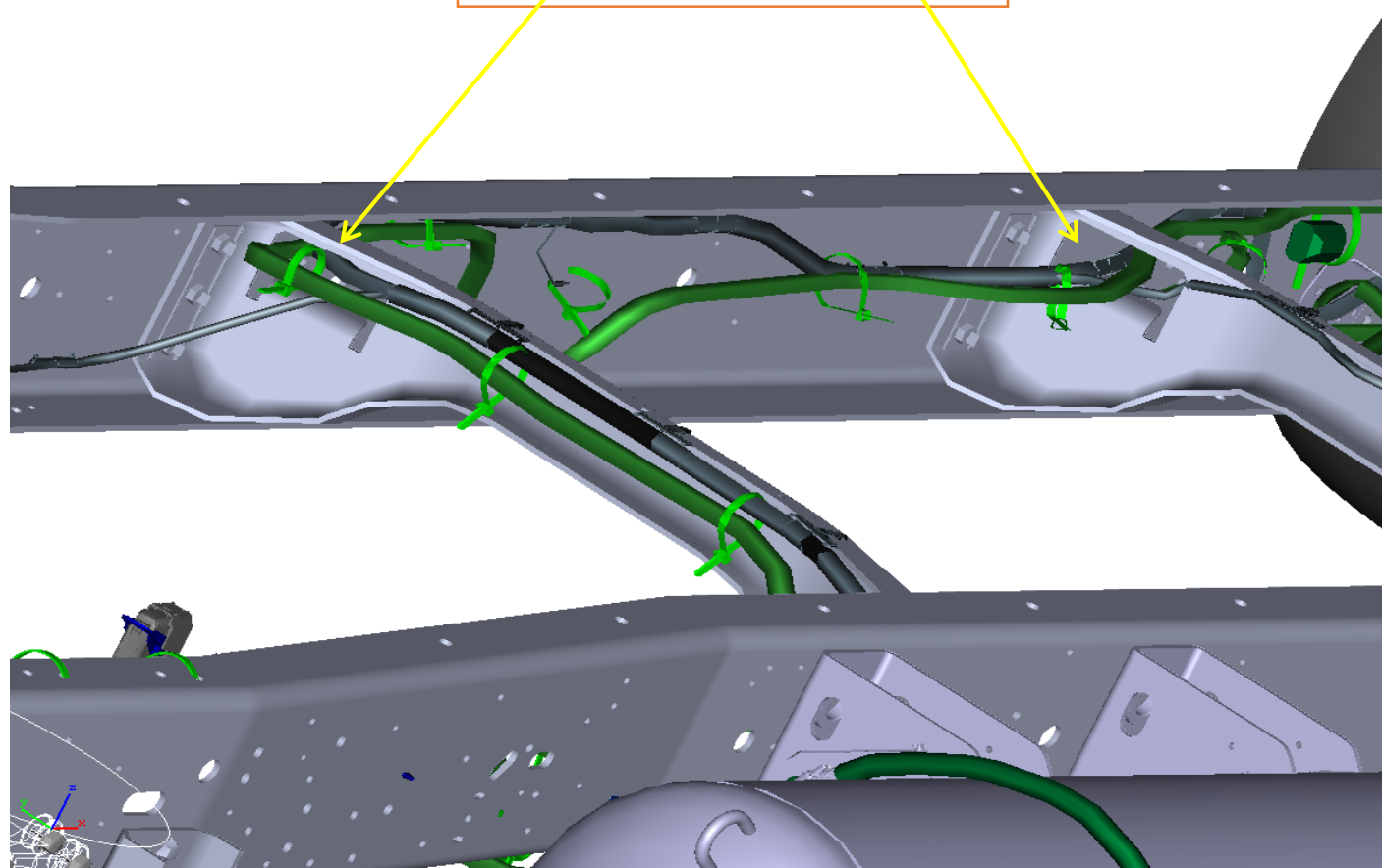

REAR FRAME HARNESS ROUTE AND RETENTION CONT.

Tie strap rear frame harness to OEM harness as shown.

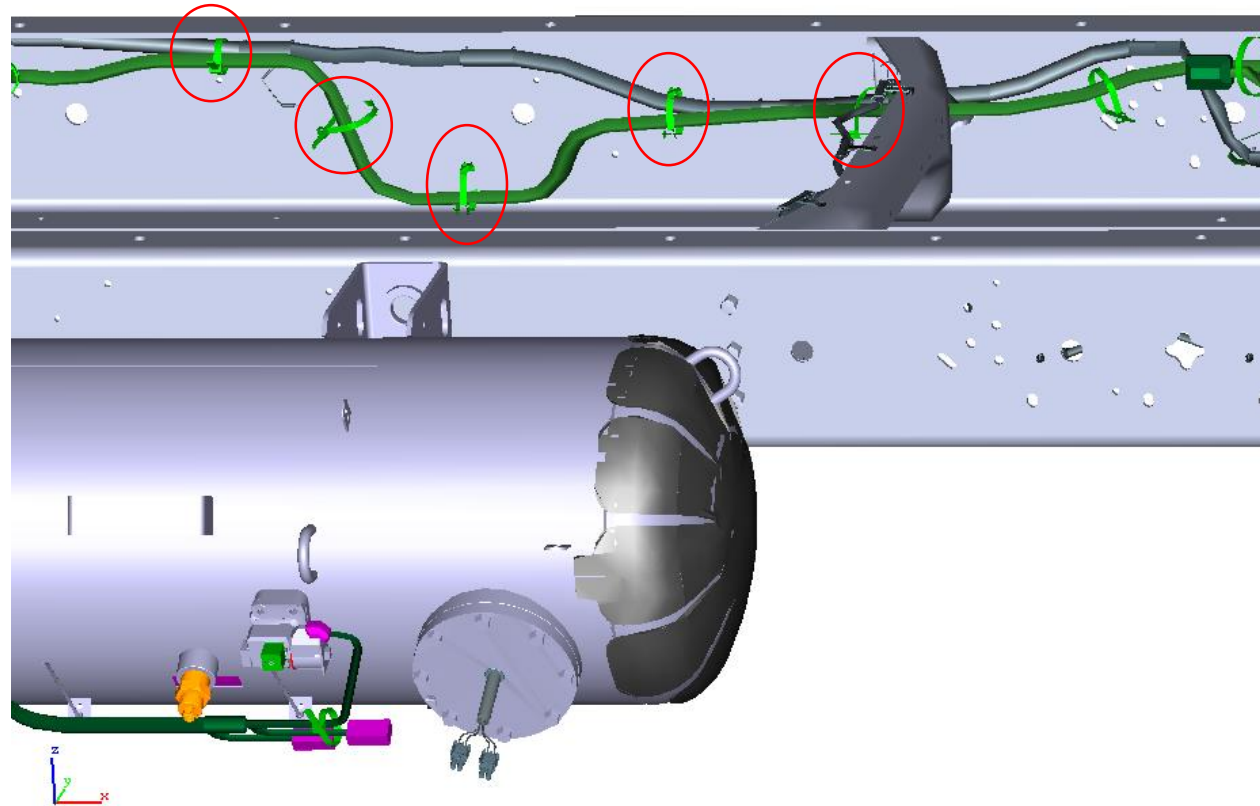

REAR FRAME HARNESS ROUTE AND RETENTION CONT.

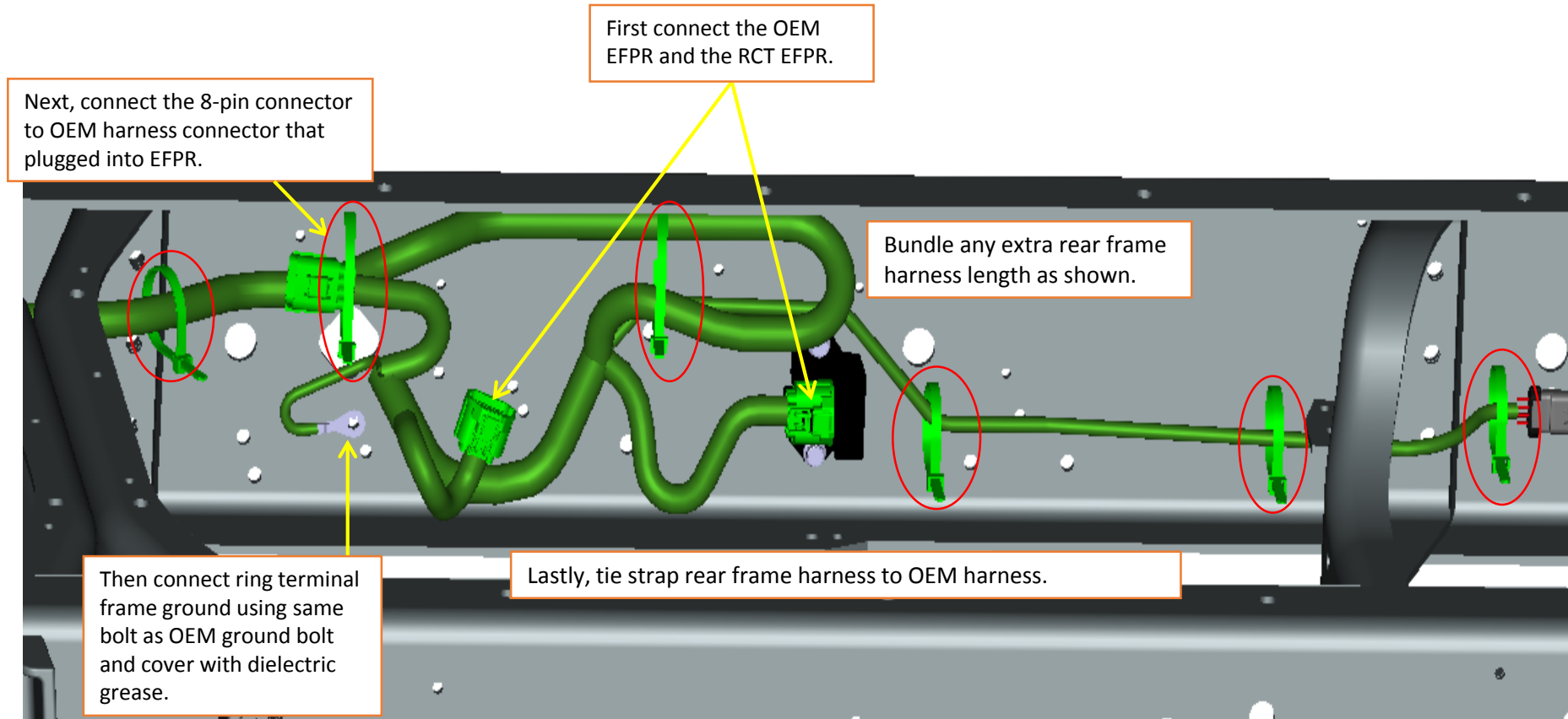

REAR FRAME HARNESS ROUTE AND RETENTION CONT.

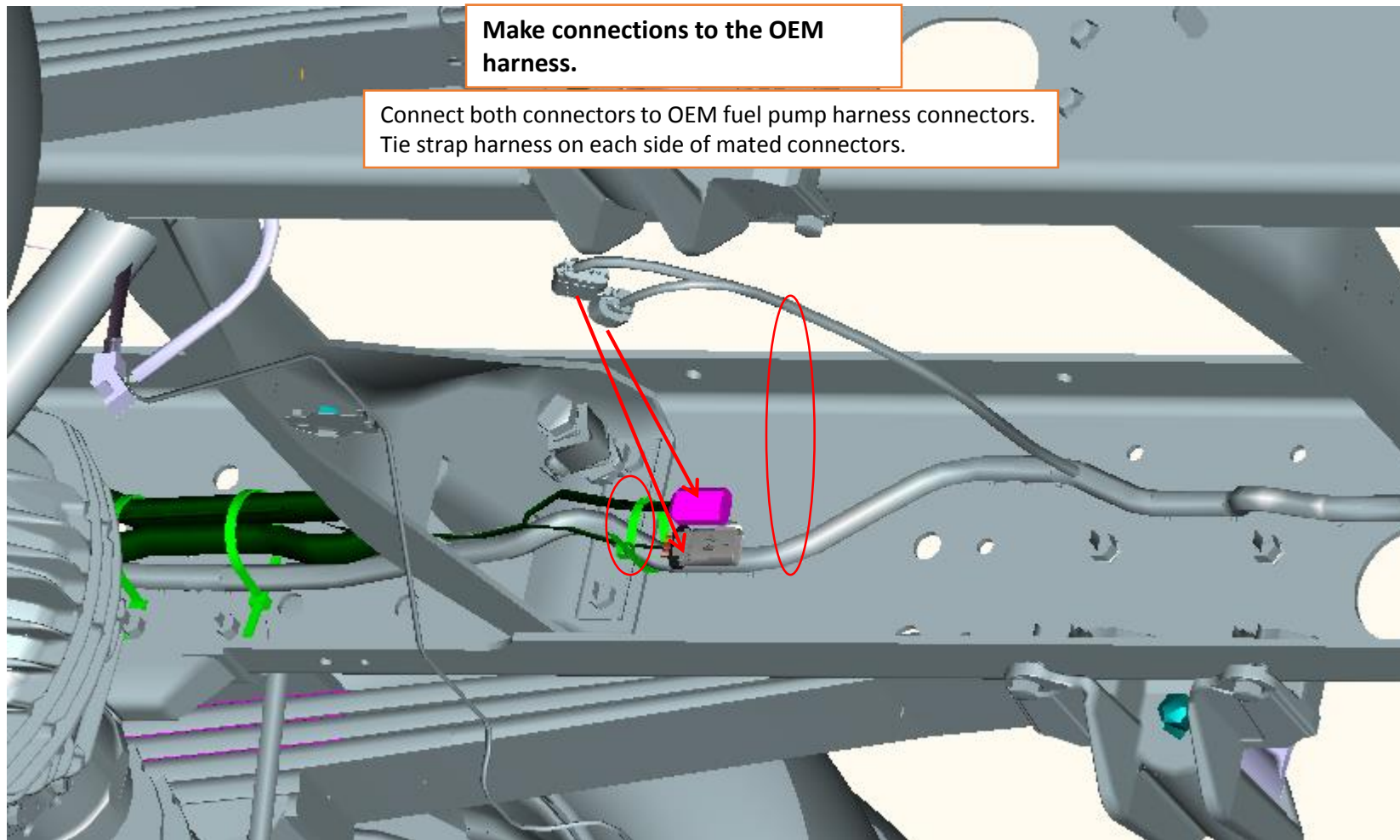

REAR FRAME HARNESS TO TANK HARNESS

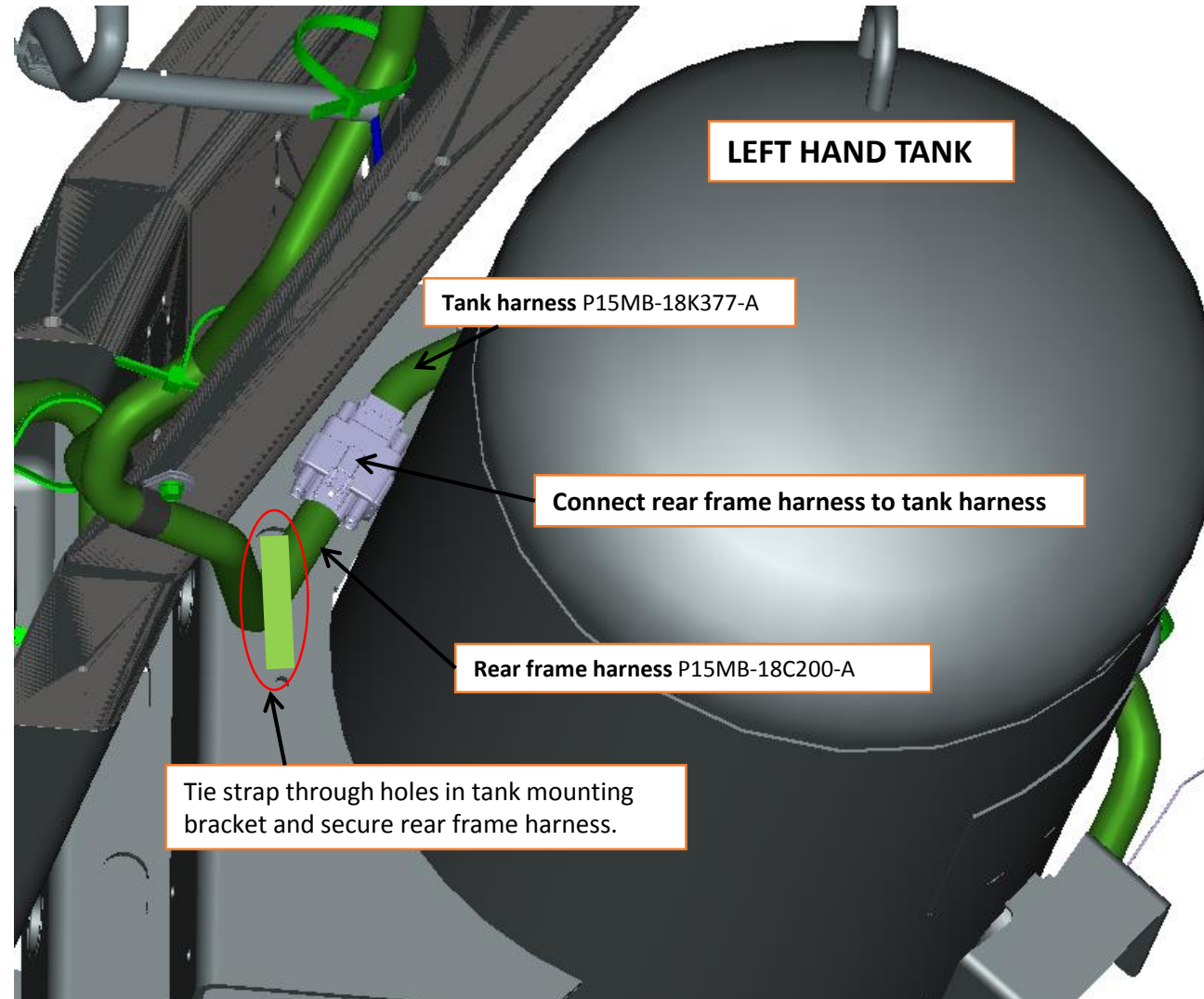

TANK HARNESS ROUTE AND RETENTION

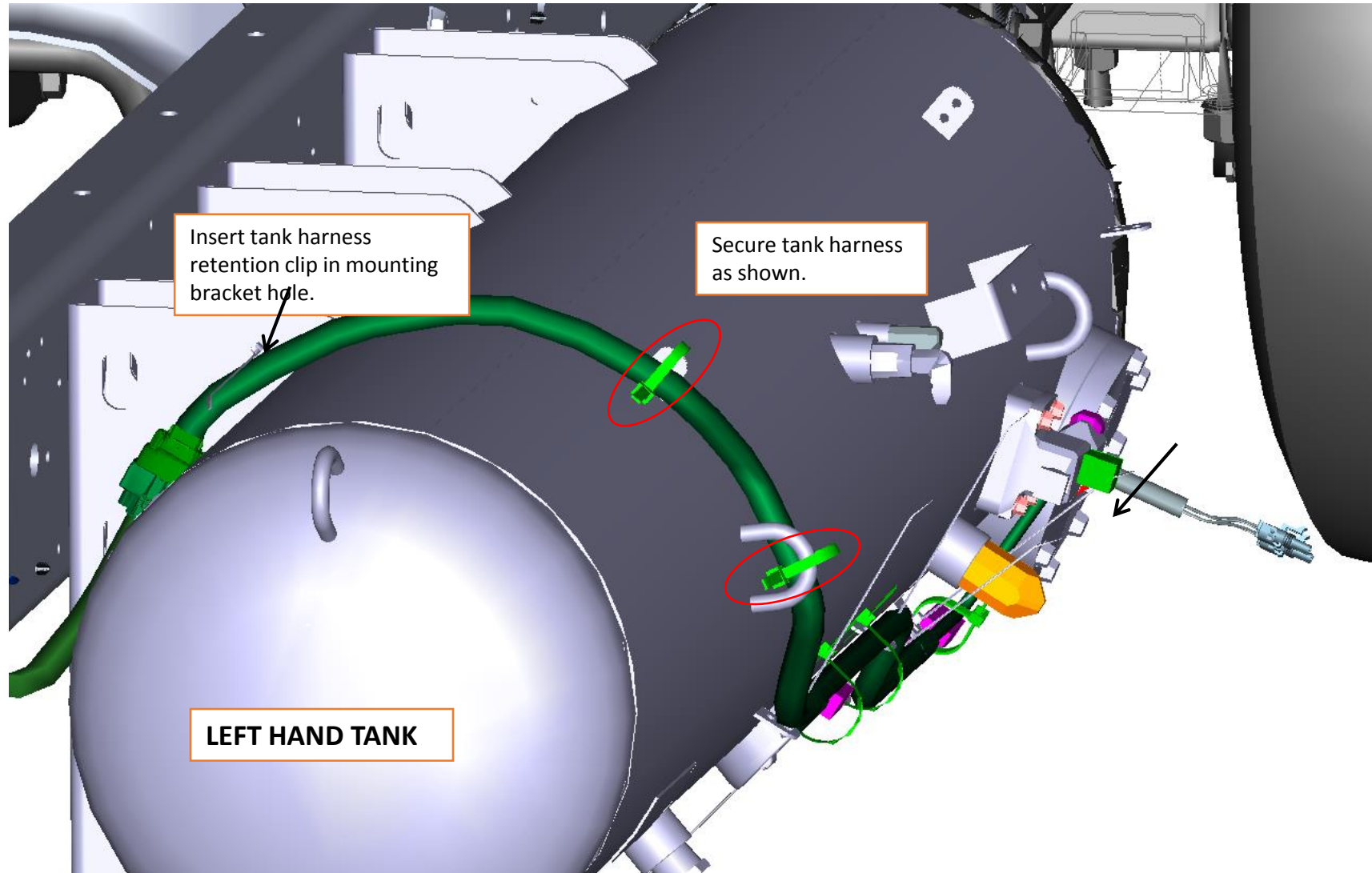

TANK HARNESS ROUTE AND RETENTION CONT.

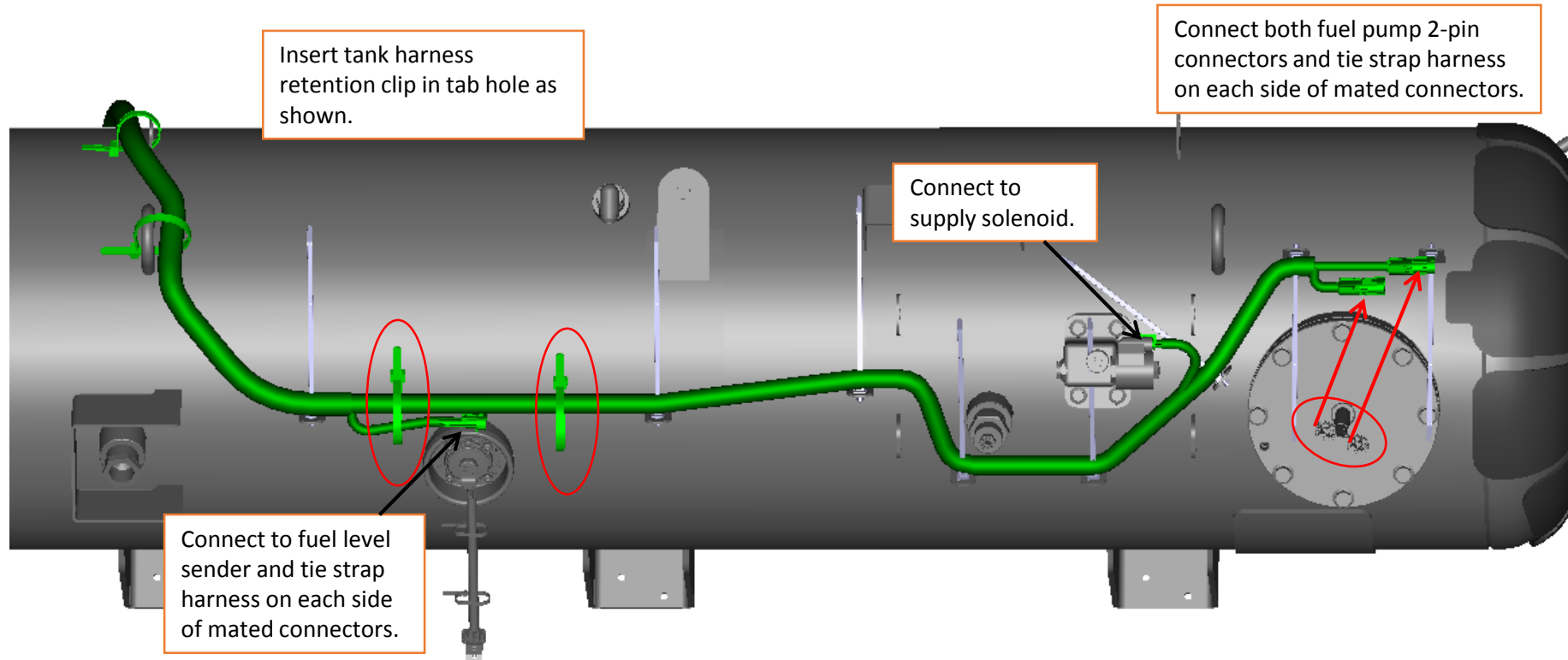

INSTALLING BADGES AND LABELS

1. Clean and dry all surfaces before applying new self-adhesive badges and labels.

P07L3-9A095-A

P07L3-9A095-IC



P11BB-01C200-B

INSTALLING BADGES AND LABELS CONT.

The annual OPD verification record label is installed near the passenger side door as shown below. The second label is the Roush modified vehicle statement label.

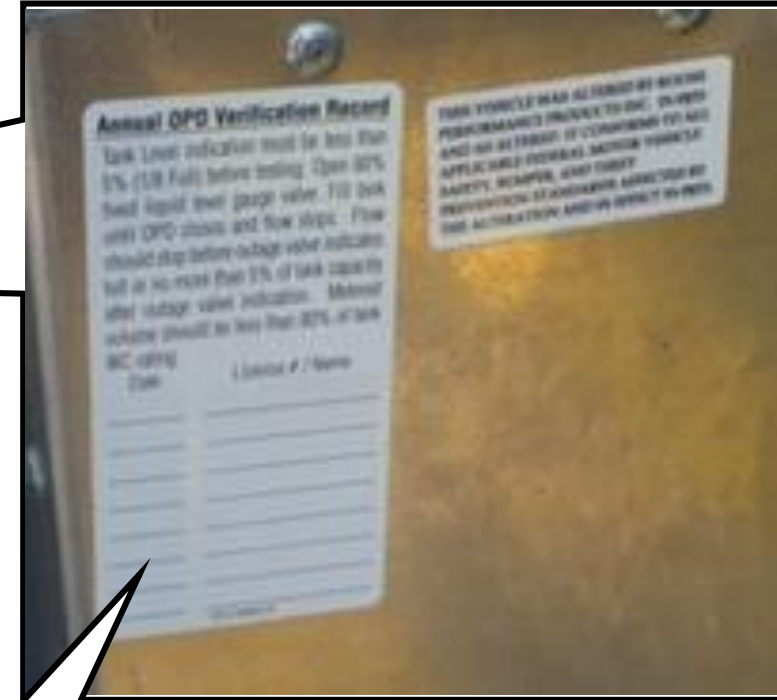

P07L3-9A095-C

INSTALLING BADGES AND LABELS CONT.

The vehicle emission control information labels (VECI) and the PCM tamper label R07100008-10-A are installed under hood on the drivers side firewall near the OEM PCM as shown below. The second PCM tamper label is installed on the dash below the steering wheel as shown below.



R07100008-10-A

INSTALLING BADGES AND LABELS CONT.

The diamond propane label D85 is installed on the rear of the vehicle as shown below.



D85

INSTALLING BADGES AND LABELS CONT.

The Roush CleanTech badge P-01G100-A is installed on the drivers side fender as shown below.















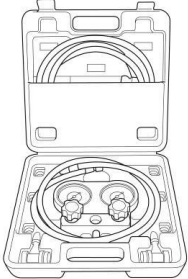

P-01G100-A

COMPLETING THE KIT INSTALLATION

1. If not done, install reprogrammed PCM following procedure in the *Ford Workshop Manual, Section 303-14, Electronic Engine Controls*.
2. Install vehicle battery and connect positive and negative terminals. Tighten to 8–12 Nm.
3. Install air induction system.
4. Connect MAF sensor.
5. Perform system leak check following established ROUSH CleanTech procedure.

SPECIAL TOOLS

							
Touch-Up Paint	Liquid Leak Detector	Premium Aerosol Undercoating	Torque Wrenches (to 22 Nm and to 200 Nm)	A/C Manifold Gauge Kit	Gloves (Approved for Propane)	Scan Tool	Reciprocating Saw
							
Hole Saw – 29 mm.	Vacuum Gauge	Vacuum Pump	Dielectric Grease	Stepless Ear Clamp Pliers	Drill Bits – 1/8", 9/32", and 5/8".	Tubing Cutter	

TANK MOUNTING MEASUREMENTS REFERENCE

